



*First Choice Solutions*®



**abis**  
precision ball bearings

## About IEC

IEC was founded in 1938 to bring to the United Kingdom engineering developments made elsewhere in the World.

Today we serve a broad band of industry with a wide range of quality products.

These are manufactured by companies of international repute who are each specialists in their own field.

We are approved to ISO 9001.

### Your benefits in working with us are

- **Competitive and cost effective solutions**
- Engineering support for you when needed
- Large stocks available with same day despatch
- Easy to deal with - our experienced, informative staff will give you fast, effective and friendly service
- No surprises - we listen and communicate
- No voicemail - personal contact
- Honest approach to warranty issues
- We treat you as an everlasting customer

Our success is built on our ability to provide our customers with quality products and standards of service that meet or exceed their expectations.

**Our aim is to provide an unrivalled service by getting it right first time and every time thereafter.**

**iec** ... *the team that cares*

***Integrity • Expertise • Commitment***

## Contents

<b>Ball Bearings</b>	<b>2 - 3</b>
<b>Metric Sizes</b>	<b>4 - 7</b>
<b>Inch Sizes</b>	<b>8 - 9</b>
<b>Extra Thin Metric Sizes - 6700, 6800 &amp; 6900</b>	<b>10 - 13</b>
<b>Large Size Stainless Steel Sizes - 6000H, 6200H &amp; 6300H</b>	<b>14 - 15</b>
<b>Extra Thin Metric &amp; Inch Sizes - ET &amp; ER</b>	<b>16</b>
<b>Thrust Sizes - FM &amp; F</b>	<b>17</b>
<b>Technical Data</b>	
<b>Bearing Materials</b>	<b>18</b>
<b>Noise Testing</b>	<b>18</b>
<b>Cages &amp; Closures</b>	<b>19</b>
<b>Radial Play</b>	<b>20</b>
<b>Internal Clearance</b>	<b>21</b>
<b>Lubricants</b>	<b>22 - 23</b>
<b>Importance of Correct Fitting of Bearings</b>	<b>24</b>
<b>Faults, Causes &amp; Remedies</b>	<b>25</b>
<b>Tolerances</b>	<b>26</b>
<b>Retaining Rings</b>	<b>27</b>
<b>Shims &amp; Spring Washers</b>	<b>28 - 29</b>
<b>Preload Springs</b>	<b>30 - 33</b>
<b>Bearing Lock Nuts</b>	<b>34 - 36</b>
<b>Product Range</b>	<b>Inside Back Cover</b>

We retain the right to alter the dimensions, performance figures and materials shown without notice, prejudice or liability.

# Bearing Reference System

# Precision Ball Bearings

### Materials

**Carbon Chrome**  
SAE 52100.  
All Types - **No Symbol**

**Stainless Steel**  
AISI 440C.  
**Refer to page 18**

Standard metric **H**  
Imperial & MR series metric **S**

### Cages

Steel Ribbon Type **J**  
Steel Crown Type **W**  
Nylon Crown Type **TW**  
Steel Rivet Type **RJ**  
Full Complement **V**  
Thrust FM Type **TP**  
Thrust F Type **TD**  
**Refer to page 19**

### Closures

Metallic Shield (Removable) **ZZS**  
Metallic Shields **ZZ**  
Rubbing Seals **2RS**  
Non-Rubbing Seals **2RU**  
Rubbing Seals (Teflon) **TTS**  
**Refer to page 19**

### Radial Play

**Miniature** **MC1, MC2, MC3, MC4,**  
(Up to 10mm bore)  
**MC5, MC6.** NOTE: MC3 is default Standard unless otherwise stated.  
**Refer to page 20**

**Standard** **C2 Normal, C3, C4, C5**  
(10mm + bore)

<b>Example 1</b>			6800	H		ZZ	MC2	3	SRL
<b>Example 2</b>	S	MR	74		W	ZZS	MC3	P6	AF2
<b>Example 3</b>	S	FR	133		T		MC4	1	SRL
<b>Example 4</b>	S	FR	8		J		C3		SRL
<b>Example 5</b>			F3-8M		TP				AF2

### Types

Inch **R**  
Inch, flanged **FR**  
Inch, extended inner **RW**  
Inch, extended inner, flanged **FRW**  
Metric (600 series) **No Symbol**  
Metric, flanged (600 series) **F**  
Metric **MR**  
Metric, flanged **MF**  
Extra Thin Metric type **ET**  
Extra Thin Inch type **ER**  
Thrust with Raceway **FM**  
Thrust without Raceway **F**  
**Refer to page 16**

### Frame Sizes

### Lubrication

Oil Aeroshell Fluid 12 **AF2**  
Grease Multemp SRL **SRL**  
**For other lubricants refer to page 22**

### Tolerances

ABEC 1 **No symbol**  
ABEC 3 **3**  
ABEC 5 **5**  
ISO Class 0 **PO**  
ISO Class 6 **P6**  
ISO Class 5 **P5**  
AFBMA Class 3P **A3P**  
AFBMA Class 5P **A5P**  
**Refer to page 26**



Our **ABIS** range covers precision ball bearings manufactured to ABEC 1 to ABEC 5 tolerances and with bore dimensions ranging from 0.6mm - 90mm.

### These are available in

- Metric and imperial sizes
- Open, shielded and sealed
- With and without flange
- High carbon chrome and stainless steel
- Full complement
- Ceramic balls

All **ABIS** precision ball bearings are produced by well established partners specialising in the manufacture of precision ball bearings approved to ISO 9001.

IEC has been closely involved with ball bearing applications in many different industries since 1938. A large stock of ABIS precision ball bearings and bearing accessories is available at our Poole premises.



## Ball Bearings

### Bearing Structure

Rolling element bearings consist of ball, roller or needle elements located between two metal rings which are then free to rotate relative to each other. They offer certain advantages over plain bushes without the higher costs of more sophisticated fluid bearings.

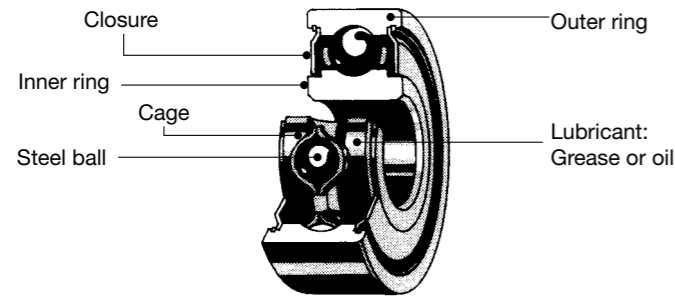

Ball bearings benefit over plain bearings in terms of torque levels, rotational accuracy and speed capability. In their standard form they can support both radial and axial loads.

### Design and Characteristics of Radial Ball Bearings

In the majority of applications the size of the ball bearing is selected according to space considerations. Usually the load capacity which the selected bearing provides is more than adequate for the continuous loads to which it is subjected. In extreme cases, or where severe vibration or shock loading is known to occur, the load carrying capability should be checked.

The form which the bearing takes is entirely determined by the overall design philosophy.

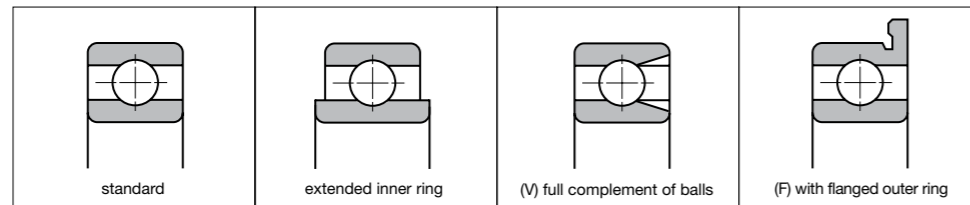

- Open or closed - is the bearing likely to become contaminated? Is escape or outgassing of lubricant an issue?
- Normal or extended inner - is there sufficient clearance axially between rotating and stationary components?
- Load - Single row radial ball bearings with balls separated by a cage can support radial loads, axial loads and tilting moments. A full complement V-type ball bearing can support only radial loads and some low axial loads. Generally a full complement bearing is used when a higher radial load is required than the standard bearing provides.

## Ball Bearings

- Speed - Maximum permissible speeds for ball bearings are mainly related to the bearing design and size, cage type, bearing internal clearance, method and type of lubrication, manufacturing accuracy, sealing methods and loads.
- Torque and noise level - Single row radial ball bearings are precision components and have low torque and noise levels.
- Inclination of inner/outer rings - Shaft and housing seats with poor accuracy, fitting errors and shaft bending might cause inclination between the inner and outer rings although the internal clearance of the bearing will permit this to a certain extent. Generally, the maximum permissible inclination between the inner and outer rings is approximately 1 in 300.
- Toughness - Bearings under load deform elastically at the contact point between the rolling element and bearing ring. This is influenced by the bearing type, size, form and load.
- Installation and removal - the single row radial ball bearing is a non-separable bearing. Therefore, shafts and housings should be so designed to enable bearing inspection and replacement when necessary.
- Axial location - improved axial location is obtained with Thrust type bearings.

### Two important internal parameters which must be considered and specified when a bearing is selected are:

**Radial Play & Internal Clearance** - the total diametrical movement from contact at one side between rings and balls to similar contact at the other side. It is normally stated in increments of tenths of a thousandth of an inch or microns. This parameter effects the torque level, the axial movement, the load carrying capacity, especially in an axial direction and, according to installation, the noise level and smoothness of the bearing. For more information see page 20-21.

**Lubrication** - the choice of oil or grease and the particular type of each, has an influence on the bearing performance. Noise level, speed, environmental temperature, load and life are some of the various factors which should be considered when selecting lubricant.

### Installation

To obtain the best performance, certain basic rules should be observed in your installation.

**Keep Parts Clean** - The clearance involved between the balls and tracks is very small and so any dirt particles present in the area of the tracks cause rough, noisy rotation and perhaps even permanent damage.

**Keep Components Round** - The inner and outer rings are generally of fairly thin section and so mating parts must be of good roundness to prevent distortion of the rings with consequent inaccurate rotation and roughness.

**Keep Assemblies Shockfree** - Since radial loads are supported on several contact points, shock loading can result in permanent deformation of the tracks and balls. The resulting craters again give rough, noisy rotation.

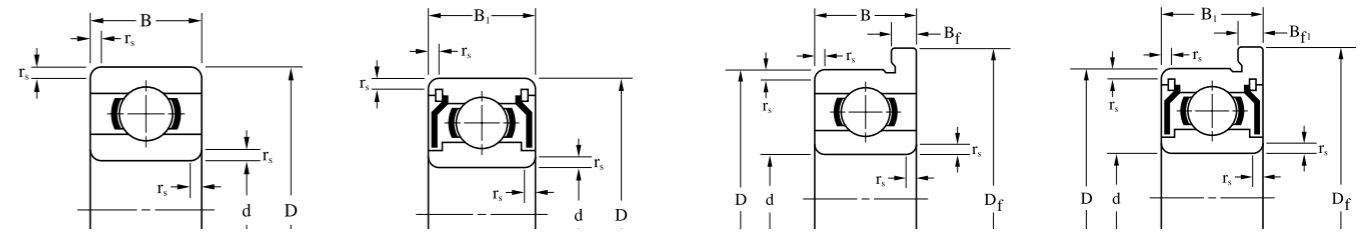

# Metric Sizes

Bore Diameter d mm	Outer Diameter D mm	Flange Diameter Df mm	Radius rs(min) mm	Open Bearings					Seal, Shield Bearings					Load Rating		Max. Speed		Cage Type	
				Width B mm	Flange Width Bf mm	ABIS Reference			Flange Shield	Width B1 mm	Flange Width Bf1 mm	Cr(N)	Cor(N)	Grease	Oil				
						Open	Flange Open	Shield								Seal			
				Open	Flange Open	Shield	2RS	2RU	TTS	x1000rpm									
0.6	2.5	-	0.05	1.0	-	68/0.6	-	-	-	-	-	-	-	68	16	142	160	W	
1.0	3	3.8	0.05	1.0	0.3	681	F681	-	-	-	-	-	-	96	26	130	150	W	
	3	-	0.05	1.5	-	MR31	-	-	-	-	-	-	-	96	26	130	150	W	
	4	5.0	0.10	1.6	0.5	691	F691	-	-	-	-	-	-	141	37	100	120	W	
1.2	4	4.8	0.10	1.8	0.4	MR41X	MF41X	MR41XZZ	-	-	-	-	2.5	-	112	33	110	130	W
1.5	4	5.0	0.05	1.2	0.4	681X	F681X	681XZZ	F681XZZ	-	-	-	2.0	0.6	112	33	100	120	W
	5	6.5	0.15	2.0	0.6	691X	F691X	691XZZ	F691XZZ	-	-	-	2.6	0.8	169	50	85	100	W
	6	7.5	0.15	2.5	0.6	601X	F601X	601XZZ	F601XZZ	-	-	-	3.0	0.8	330	99	75	90	W
2.0	4	-	0.05	1.2	-	672	-	672ZZ	-	-	-	2.0	-	124	40	91	104	W	
	5	6.1	0.08	1.5	0.5	682	F682	682ZZ	F682ZZ	-	-	-	2.3	0.6	169	50	85	100	W
	5	6.2	0.10	2.0	0.6	MR52	MF52	MR52ZZ	MF52ZZ	-	-	-	2.5	0.6	169	50	85	100	W
	6	7.5	0.15	2.3	0.6	692	F692	692ZZ	F692ZZ	-	-	TTS	3.0	0.8	330	99	75	90	W,J,TW
	6	7.2	0.15	2.5	0.6	MR62	MF62	MR62ZZ	-	-	-	2.5	-	330	99	75	90	WJ	
	7	8.2	0.15	2.5	0.6	MR72	MF72	MR72ZZS	MF72ZZS	-	-	TTS	3.0	0.6	386	129	63	75	W
2.5	7	8.5	0.15	2.8	0.7	602	F602	602ZZS	F602ZZS	-	-	TTS	3.5	0.9	386	129	60	71	W
	6	7.1	0.08	1.8	0.5	682X	F682X	682XZZ	F682XZZ	-	-	-	2.6	0.8	209	74	71	80	W
	7	8.5	0.15	2.5	0.7	692X	F692X	692XZZS	F692XZZS	-	-	TTS	3.5	0.9	386	129	63	75	W
	8	9.2	0.20	2.5	0.6	MR82X	MF82X	-	-	-	-	-	-	558	180	60	67	W	
3.0	8	9.5	0.15	2.8	0.7	602X	F602X	602XZZ	F602X	-	-	-	4.0	0.9	552	177	60	71	W
	6	7.2	0.10	2.0	0.6	MR63	MF63	MR63ZZ	MF63ZZ	-	-	-	2.5	0.6	209	74	71	80	W
	7	8.1	0.10	2.0	0.5	683	F683	683ZZ	F683ZZ	-	-	TTS <sup>(4)</sup>	3.0	0.8	311	112	63	75	W
	8	9.2	0.15	2.5	0.6	MR83	MF83	MR83ZZ	-	-	-	3.0	-	395	141	60	67	J	
	8	9.5	0.15	3.0	0.7	693	F693	693ZZ	F693ZZ	2RS	-	-	4.0	0.9	558	180	60	67	W,J,TW
	9	10.2*	0.20	2.5	0.6	MR93	MF93	MR93ZZ	MF93ZZ	-	-	-	4.0	0.8	571	189	56	67	W
	9	10.5	0.15	3.0	0.7	603	F603	603ZZ	F603ZZ	-	-	-	5.0	1.0	571	189	56	67	W
	10	11.5	0.15	4.0	1.0	623	F623	623ZZ	F623ZZ	2RS	2RU	-	4.0	1.0	631	219	50	60	J,TW
4.0	13	-	0.20	5.0	-	633	-	633ZZ	-	2RS	2RU	-	5.0	-	1301	488	40	48	J
	7	8.2	0.10	2.0	0.6	MR74	MF74	-	-	-	-	-	-	311	115	60	67	W	
	7	8.2	0.10	-	-	-	-	MR74ZZ	MF74ZZ	-	-	-	2.5	0.6	255	108	60	67	W
			0.15			MR84	MF84												
	8	9.2	0.10	2.0	0.6			MR84ZZ	MF84ZZ	-	-	-	3.0	0.6	395	141	56	67	W,J,TW
	9	10.3	0.10	2.5	0.6	684	F684	684ZZ	F684ZZ	2RS	2RU	TTS	4.0	1.0	641	227	53	63	W,J,TW
			0.20			MR104	MF104												
	10	11.2*	0.15	3.0	0.6			MR104ZZ	MF104ZZ	2RS	2RU	-	4.0	0.8	711	272	48	56	J
	11	12.5	0.15	4.0	1.0	694	F694	694ZZ	F694ZZ	2RS	2RU	-	4.0	1.0	957	350	48	56	J
	12	13.5	0.20	4.0	1.0	604	F604	604ZZ	F604ZZ	2RS	2RU	-	4.0	1.0	957	350	48	56	J
	13	15.0	0.20	5.0	1.0	624	F624	624ZZ	F624ZZ	2RS	2RU	-	5.0	1.0	1301	488	40	48	J
16	18.0	0.30	5.0	1.0	634	F634	634ZZ	F634ZZ	2RS	2RU	TTS	5.0	1.0	1340	523	36	43	J	

\*This dimension is increased by 0.4mm for shielded or seal version.  
Bearings also available with single shield or seal: suffix Z, RS, RU or TS.

Bearings also available with stainless material: suffix S or H.  
TTS<sup>(4)</sup> uses smaller ball, load rating is lower than standard

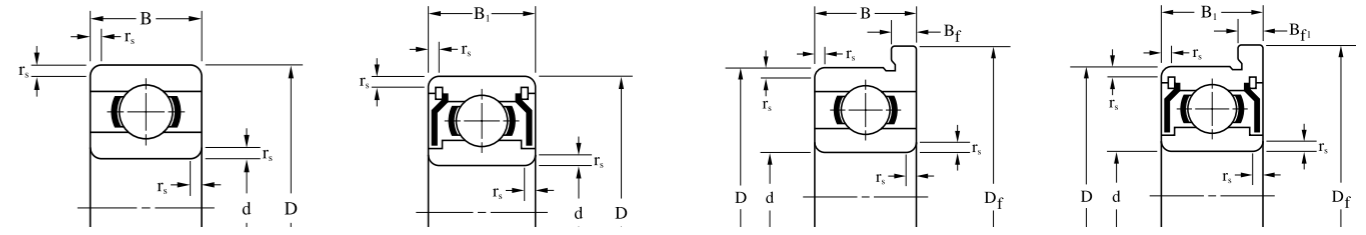

# Metric Sizes

Bore Diameter d	Outer Diameter D	Flange Diameter D <sub>f</sub>	Radius r <sub>s</sub> (min)	Open Bearings		Seal, Shield Bearings								Load Rating		Max. Speed		Cage Type			
				Width B	Flange Width B <sub>f</sub>	ABIS Reference				Width B <sub>1</sub>	Flange Width B <sub>f1</sub>	Cr(N)	Cor(N)	Grease	Oil						
						Open	Flange Open	Shield	Flange Shield							Seal					
														2RS	2RU	TTS	x1000rpm				
mm	mm	mm	mm	mm	mm																
5.0	8	9.2	0.10	2.0	0.6	MR85	MF85	-	-	-	-	-	-	-	-	308	120	53	63	W	
	8	9.2	0.10	-	-	-	-	MR85ZZ	MF85ZZ	-	-	TTS	2.5	0.6	218	90	53	63	W		
	9	10.2	0.15	2.5	0.6	MR95	MF95	MR95ZZ	MF95ZZ	-	-	TTS	3.0	0.6	431	169	50	60	W		
	10	11.2*	0.15	3.0	0.6	MR105	MF105	MR105ZZ	MF105ZZ	2RS	2RU	-	4.0	0.8	431	169	50	60	W		
	11	12.6	0.15	-	-	-	-	MR115ZZ	MF115ZZ	2RS	2RU	-	4.0	0.8	716	282	45	53	J		
	11	12.5	0.15	3.0	0.8	685	F685	685ZZ	F685ZZ	2RS	2RU	-	5.0	1.0	716	282	45	53	J,TW		
	13	15.0	0.20	4.0	1.0	695	F695	695ZZ	F695ZZ	2RS	2RU	TTS <sup>(4)</sup>	4.0	1.0	1077	432	43	50	J		
	14	16.0	0.20	5.0	1.0	605	F605	605ZZ	F605ZZ	2RS	2RU	-	5.0	1.0	1329	507	40	50	J,TW		
	16	18.0	0.30	5.0	1.0	625	F625	625ZZ	F625ZZ	2RS	2RU	TTS	5.0	1.0	1729	675	36	43	J,TW		
19	22.0	0.30	6.0	1.5	635	F635	635ZZ	F635ZZ	2RS	2RU	-	6.0	1.5	2336	896	32	40	J,TW			
6.0	10	11.2	0.15	2.5	0.6	MR106	MF106	-	-	-	-	-	-	-	-	496	218	45	53	W	
			0.20			MR126	MF126	MR106ZZ	MF106ZZ	-	-	TTS <sup>(4)</sup>	3.0	0.6							
	12	13.2*	0.15	3.0	0.6			MR126ZZ	MF126ZZ	2RS	2RU	-	4.0	0.8	716	295	43	50	W,J,TW		
	13	15.0	0.15	3.5	1.0	686	F686	686ZZ	F686ZZ	2RS	2RU	TTS	5.0	1.1	1082	442	40	50	J,TW		
	15	17.0	0.20	5.0	1.2	696	F696	696ZZ	F696ZZ	2RS	2RU	TTS	5.0	1.2	1340	523	40	45	J		
	16	-	0.20	5.0	-	-	-	696AZZ	-	2RS	2RU	-	5.0	-	1340	523	40	45	J		
	17	19.0	0.30	6.0	1.2	606	F606	606ZZ	F606ZZ	2RS	2RU	-	6.0	1.2	2263	846	38	45	J		
	19	22.0	0.30	6.0	1.5	626	F626	626ZZ	F626ZZ	2RS	2RU	TTS <sup>(4)</sup>	6.0	1.5	2336	896	32	40	J,TW		
22	-	0.30	7.0	-	636	-	636ZZ	-	2RS	2RU	-	7.0	-	3333	1423	30	36	J,TW			
7.0	11	12.2	0.15	2.5	0.6	MR117	MF117	-	-	-	-	-	-	-	-	455	202	43	50	W	
			0.20			MR137	MF137	MR117ZZS	MF117ZZS	-	-	TTS	3.0	0.6							
	13	14.2*	0.15	3.0	0.6			MR137ZZ	MF137ZZ	-	-	TTS	4.0	0.8	541	276	40	48	W		
	14	16.0	0.15	3.5	1.0	687	F687	687ZZ	F687ZZ	2RS	2RU	TTS	5.0	1.1	1173	513	40	50	J		
	17	19.0	0.30	5.0	1.2	697	F697	697ZZ	F697ZZ	2RS	2RU	-	5.0	1.2	1605	719	36	43	J		
	19	22.0	0.30	6.0	1.5	607	F607	607ZZ	F607ZZ	2RS	2RU	TTS <sup>(4)</sup>	6.0	1.5	2336	896	36	43	J,TW		
	22	25.0	0.30	7.0	1.5	627	F627	627ZZ	F627ZZ	2RS	2RU	TTS	7.0	1.5	3287	1379	30	36	J,TW		
26	-	0.30	9.0	-	637	-	637ZZ	F637ZZ	2RS	2RU	-	9.0	-	4563	1983	28	34	J			
8.0	12	13.2*	0.15	2.5	0.6	MR128	MF128	-	-	-	-	-	-	-	-	543	274	40	48	W	
			0.20			MR148	MF148	MR128ZZ	MF128ZZ	-	-	TTS	3.5	0.8							
	14	15.6	0.15	3.5	0.8			MR148ZZ	MF148ZZ	2RS	2RU	-	4.0	0.8	817	386	38	45	J		
	16	18.0	0.20	4.0	1.0	688	F688	688ZZ	F688ZZ	2RS	2RU	TTS	5.0	1.1	1252	592	36	43	J,TW		
	19	22.0	0.30	6.0	1.5	698	F698	698ZZ	F698ZZ	2RS	2RU	-	6.0	1.5	2237	917	36	43	J		
	22	25.0	0.30	7.0	1.5	608	F608	608ZZ	F608ZZ	2RS	2RU	TTS	7.0	1.5	3293	1379	34	40	J,TW		
	24	-	0.30	8.0	-	628	-	628ZZ	-	2RS	2RU	-	8.0	-	3333	1423	28	34	J		
28	-	0.30	9.0	-	638	-	638ZZ	-	2RS	2RU	-	9.0	-	4563	1983	28	34	J			
9.0	14	15.5	0.10	3.0	0.8	679	F679	679ZZS	F679ZZS	-	-	TTS	4.5	0.8	919	468	36	42	J		
	17	19.0	0.20	4.0	1.0	689	F689	689ZZ	F689ZZ	2RS	2RU	-	5.0	1.1	1327	668	36	43	J		
	20	23.0	0.30	6.0	1.5	699	F699	699ZZ	F699ZZ	2RS	2RU	-	6.0	1.5	2467	1081	34	40	J		
	24	27.0	0.30	7.0	1.5	609	F609	609ZZ	F609ZZ	2RS	2RU	-	7.0	1.5	3356	1444	32	38	J		
	26	-	0.60 <sup>(5)</sup>	8.0	-	629	-	629ZZ	-	2RS	2RU	-	8.0	-	4563	1983	28	34	J		
	30	-	0.60	10.0	-	639	-	639ZZ	-	2RS	2RU	-	10.0	-	4659	2080	24	30	J		

\*This dimension is increased by 0.4mm for shielded or sealed version.  
Bearings also available with single shield or seal: suffix Z, RS, RU or TS.  
Bearings also available with stainless material: S or H.

TTS<sup>(4)</sup> uses smaller ball, load rating is lower than standard.  
Value<sup>(5)</sup> is not based upon JIS B 1521.

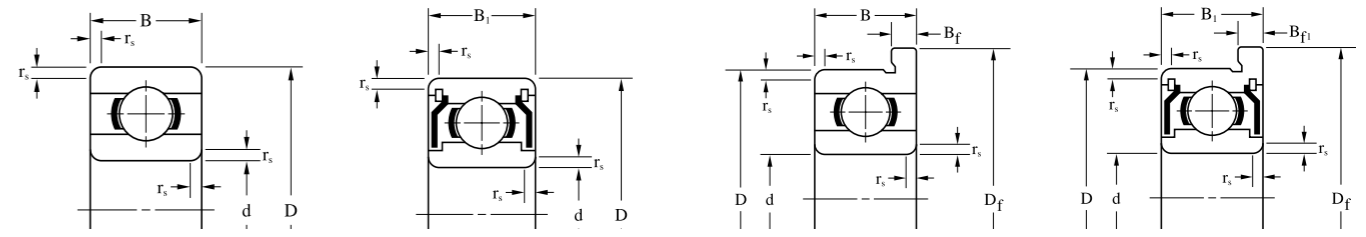

# Inch Sizes

Bore Diameter d	Outer Diameter D	Flange Diameter Df	Radius rs(min)	Open Bearings				Seal, Shield Bearings					Load Rating		Max. Speed		Cage Type		
				Width B	Flange Width Bf	ABIS Reference		Shield	Flange Shield	Seal			Width B1	Flange Width Bf1	Cr(N)	Cor(N)		Grease	Oil
						Open	Flange Open			2RS	2RU	TTS							
inch	inch	inch	inch	inch	inch							inch	inch			x1000rpm			
0.0400	0.1250	0.1710	0.0039	0.0469	0.0130	R09	FR09	-	-	-	-	-	-	-	106	28	130	150	W
0.0469	0.1562	0.2030	0.0039	0.0625	0.0130	R0*	FR0*	R0ZZ*	FR0 ZZ*	-	-	-	0.0937	0.0310	112	33	110	130	W
0.0550	0.1875	0.2340	0.0039	0.0781	0.0230	R1*	FR1*	R1ZZ*	FR1ZZ*	-	-	-	0.1094	0.0310	232	67	90	110	W
0.0781	0.2500	0.2960	0.0039	0.0937	0.0230	R1-4*	FR1-4*	R1-4ZZ*	FR1-4ZZ*	-	-	TTS	0.1406	0.0310	284	96	67	80	W
0.0937	0.1875	0.2340	0.0039	0.0625	0.0180	R133	FR133	-	-	-	-	-	-	-	189	60	80	95	W
	0.1875	0.2340	0.0039	-	-	-	-	R133ZZS*	FR133ZZS*	-	-	-	0.0937	0.0310	144	53	80	95	W
	0.3125	0.3590	0.0059	0.1094	0.0230	R1-5*	FR1-5*	R1-5ZZS*	FR1-5ZZS*	-	-	TTS	0.1406	0.0310	552	176	60	71	W
0.1250	0.2500	0.2960	0.0039	0.0937	0.0230	R144J*	FR144J*	R144JZZ*	FR144JZZ*	-	-	TTS	0.1094	0.0310	311	110	67	80	J
	0.2500	0.2960	0.0039	0.0937	0.0230	R144*	FR144*	R144ZZ*	FR144ZZ*	-	-	TTS	0.1094	0.0310	284	96	67	80	W
	0.3125	0.3590	0.0039	0.1094	0.0230	R2-5*	FR2-5*	R2-5ZZ*	FR2-5ZZ*	-	-	TTS	0.1406	0.0310	558	180	60	67	W,J
	0.3750	0.4220	0.0059	0.1094	0.0230	R2-6*	FR2-6*	R2-6ZZ*	FR2-6ZZ*	2RS	2RU	TTS	0.1406	0.0310	640	227	53	63	J
	0.3750	0.4400	0.0118	0.1562	0.0300	R2*	FR2*	R2ZZ*	FR2ZZ*	2RS	2RU	-	0.1562	0.0300	631	219	56	67	J
	0.5000	-	-	0.0118	0.1719	-	R2A	-	R2AZZ	-	-	-	0.1719	-	640	227	53	63	J
0.1562	0.3125	0.3590	0.0039	0.1094	0.0230	R155*	FR155*	R155ZZS*	FR155ZZS*	-	-	-	0.1250	0.0360	359	150	53	63	W
0.1875	0.3125	0.3590	0.0039	0.1094	0.0230	R156*	FR156*	R156ZZS*	FR156ZZS*	-	-	TTS	0.1250	0.0360	359	150	53	63	W
	0.3750	0.4220	0.0039	0.1250	0.0230	R166*	FR166*	R166ZZ*	FR166ZZ*	-	-	TTS	0.1250	0.0310	709	272	50	60	J
	0.5000	0.5650	0.0118	0.1960	0.0420	-	FR3*	-	-	-	-	-	-	1301	488	43	53	J	
	0.5000	0.5650	0.0118	0.1562	-	R3*	-	R3ZZ*	FR3ZZ*	2RS	2RU	TTS	0.1960	0.0420	1301	488	43	53	J
	0.6250	-	-	0.0118	0.1960	-	R3A	-	R3AZZ	-	2RS	2RU	-	0.1960	-	1480	621	38	45
0.2500	0.3750	0.4220	0.0039	0.1250	0.0230	R168*	FR168*	R168ZZS*	FR168ZZS*	-	-	TTS	0.1250	0.0360	373	172	48	56	W
	0.5000	0.5470	0.0059	0.1250	0.0230	R188*	FR188*	R188ZZ*	FR188ZZ*	2RS	2RU	TTS	0.1875	0.0450	1082	442	40	50	J
	0.6250	0.6900	0.0118	0.1960	0.0420	R4*	FR4*	R4ZZ*	FR4ZZ*	2RS	2RU	TTS	0.1960	0.0633	1480	621	38	45	J
	0.7500	-	-	0.0157	0.2188	-	R4A	-	R4AZZ	-	2RS	2RU	-	0.2812	-	2336	896	36	43
0.3125	0.5000	0.5470	0.0059	0.1562	0.0310	R1810*	FR1810	R1810ZZS	FR1810ZZS*	-	-	TTS	0.1562	0.0310	542	276	40	48	W
0.3750	0.8750	0.9690	0.0157	0.2188	0.0620	R6	FR6*	R6ZZ	FR6ZZ*	2RS	2RU	TTS	0.2812	0.0620	3332	1411	32	38	J
0.5000	1.1250	1.2252	0.0157	0.2500	0.0620	R8	FR8*	R8ZZ	FR8ZZ*	2RS	2RU	TTS	0.3125	0.0620	5108	2413	27	32	J
0.6250	1.3750	1.4900	0.0315	0.2812	-	R10	-	R10ZZ	FR10ZZ	2RS	2RU	-	0.3438	0.0687	5999	3265	21	25	RJ
0.7500	1.6250	-	0.0315	0.3125	-	R12	-	R12ZZ	-	2RS	2RU	-	0.4375	-	9384	5057	17	21	RJ,TW

\*Available with inner ring width extended by 0.0156" (0.3962mm) each side.  
 Bearings also available with single shield or seal: suffix Z, RS, RU or TS.  
 Bearings also available with stainless material: prefix S.

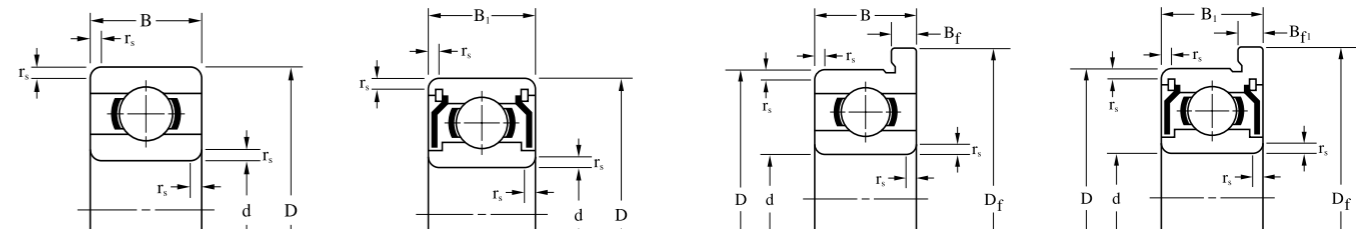

## Extra Thin Metric Sizes

6700 6800 6900

Bore Diameter d	Outer Diameter D	Flange Diameter Df	Radius r <sub>s</sub> (min)	Width B	Flange Width Bf	ABIS Reference		ABIS Reference					Load Rating		Max. Speed		Cage Type
						Open	Flange Open	Shield	Flange Shield	Seal			Cr(N)	Cor(N)	Grease	Oil	
										2RS	2RU	TTS					
10	15	16.5	0.15	3	0.8	6700	F6700	-	-	-	-	-	855	435	15	17	W
	15	16.5	0.15	4	0.8	-	-	6700ZZS	F6700ZZS	2RS	-	TTS	855	435	15	17	W
	19	21.0	0.30	5	1.0	6800	F6800	6800ZZ	F6800ZZ	2RS	2RU	-	1716	840	37	43	J,TW
	19	21.0	0.30	7	1.5	63800	F63800	63800ZZ	F63800ZZ	2RS	2RU	-	1716	840	37	43	J,TW
	22	25.0	0.30	6	1.5	6900	F6900	6900ZZ	F6900ZZ	2RS	2RU	-	2695	1273	34	41	J
12	18	19.5	0.20	4	0.8	6701	F6701	6701ZZS	F6701ZZS	2RS	-	TTS	926	530	13	15	W
	21	23.0	0.30	5	1.1	6801	F6801	6801ZZ	F6801ZZ	2RS	2RU	-	1915	1041	33	39	J,TW
	21	23.0	0.30	7	1.5	63801	F63801	63801ZZ	F63801ZZ	2RS	2RU	-	1915	1041	33	39	J,TW
	24	26.5	0.30	6	1.5	6901	F6901	6901ZZ	F6901ZZ	2RS	2RU	-	2886	1466	31	36	J
15	21	22.5	0.20	4	0.8	6702	F6702	6702ZZS	F6702ZZS	2RS	-	TTS	937	582	11	13	W
	24	26.0	0.30	5	1.1	6802	F6802	6802ZZ	F6802ZZ	2RS	2RU	-	2073	1253	28	33	J,TW
	24	26.0	0.30	7	1.5	63802	F63802	63802ZZ	F63802ZZ	2RS	2RU	-	2073	1253	28	33	J,TW
	28	30.5	0.30	7	1.5	6902	F6902	6902ZZ	F6902ZZ	2RS	2RU	-	4321	2259	26	30	J
17	23	24.5	0.20	4	0.8	6703	F6703	6703ZZS	F6703ZZS	2RS	-	TTS	1000	658	9.5	11	W
	26	28.0	0.30	5	1.1	6803	F6803	6803ZZ	F6803ZZ	2RS	2RU	-	2233	1456	26	30	J,TW
	26	28.0	0.30	7	1.5	63803	F63803	63803ZZ	F63803ZZ	2RS	2RU	-	2233	1456	26	30	J,TW
	30	32.5	0.30	7	1.5	6903	F6903	6903ZZ	F6903ZZ	2RS	2RU	-	4588	2565	23	38	J
20	27	28.5	0.20	4	0.8	6704	F6704	6704ZZS	F6704ZZS	2RS	-	TTS	1402	729	8.5	10	W
	32	35.0	0.30	7	1.5	6804	F6804	6804ZZ	F6804ZZ	2RS	2RU	-	4015	2462	21	25	J,RJ <sup>(3)</sup>
	32	35.0	0.30	10	2.0	63804	F63804	63804ZZ	F63804ZZ	2RS	2RU	-	4015	2462	21	25	J,RJ <sup>(3)</sup>
	37	40.0	0.30	9	2.0	6904	F6904	6904ZZ	F6904ZZ	2RS	2RU	-	6381	3682	19	23	RJ
25	32	34.0	0.20	4	1.0	6705	F6705	-	-	2RS	-	-	1091	838	7	8	W
	37	40.0	0.30	7	1.5	6805	F6805	6805ZZ	F6805ZZ	2RS	2RU	-	4303	2932	18	21	J,RJ <sup>(3)</sup>
	37	40.0	0.30	10	2.0	63805	F63805	63805ZZ	F63805ZZ	2RS	2RU	-	4303	2932	18	21	J,RJ <sup>(3)</sup>
	42	45.0	0.30	9	2.0	6905	F6905	6905ZZ	F6905ZZ	2RS	2RU	-	7001	4540	16	19	RJ
30	37	39.0	0.20	4	1.0	6706	F6706	-	-	-	2RU	-	1143	947	5.5	7	W
	42	45.0	0.30	7	1.5	6806	F6806	6806ZZ	F6806ZZ	2RS	2RU	-	4538	3402	15	18	J,RJ <sup>(3)</sup>
	42	45.0	0.30	10	2.0	63806	F63806	63806ZZ	F63806ZZ	2RS	2RU	-	4538	3402	15	18	J,RJ <sup>(3)</sup>
	47	50.0	0.30	9	2.0	6906	F6906	6906ZZ	F6906ZZ	2RS	2RU	-	7242	5003	14	17	RJ

Bearings also available with single shield or seal: suffix Z, RS, RU or TS.  
Bearings also available with stainless material: suffix H.

<sup>(3)</sup> Carbon Chrome bearings use RJ type retainer, stainless bearings use J type cage.



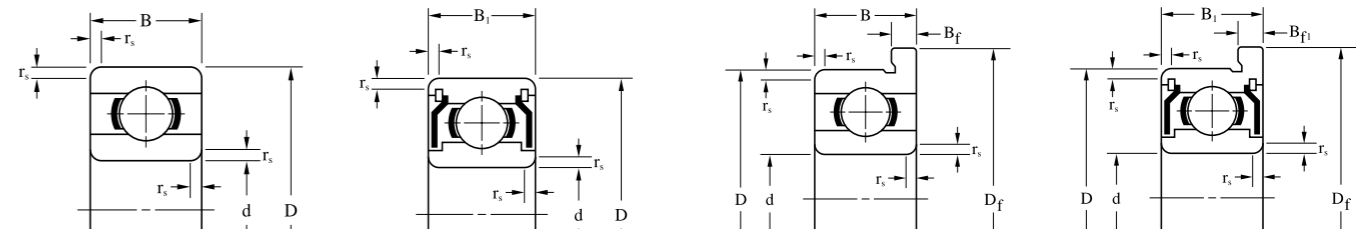

## Extra Thin Metric Sizes

6700 6800 6900

Bore Diameter d	Outer Diameter D	Flange Diameter D <sub>f</sub>	Radius r <sub>s</sub> (min)	Width B	Flange Width B <sub>f</sub>	ABIS Reference		ABIS Reference					Load Rating		Max. Speed		Cage Type
						Open	Flange Open	Shield	Flange Shield	Seal			Cr(N)	Cor(N)	Grease	Oil	
mm	mm	mm	mm	mm	mm					2RS	2RU	TTS			x1000rpm		
35	44	-	0.30	5	-	6707	-	-	-	2RS	-	-	1866	1635	4.9	6.0	W
	47	50.0	0.30	7	1.5	6807	F6807	6807ZZ	F6807ZZ	2RS	2RU	-	4729	3821	13.0	16.0	J,RJ <sup>(3)</sup>
	55	58.0	0.60	10	2.5	6907	F6907	6907ZZ	F6907ZZ	2RS	2RU	-	10900	7818	12.0	14.0	RJ
40	50	-	0.30	6	-	6708	-	-	-	2RS	-	-	2516	2233	4.3	5.0	W
	52	55.0	0.30	7	1.5	6808	F6808	6808ZZ	F6808ZZ	2RS	2RU	-	4923	4178	12.0	14.0	J
	62	65.0	0.60	12	2.5	6908	F6908	6908ZZ	F6908ZZ	2RS	2RU	-	13678	9968	11.0	13.0	RJ
45	55	-	0.30	6	-	6709	-	-	-	2RS	-	-	2580	2397	3.9	4.6	W
	58	61	0.30	7	1.5	6809	F6809	6809ZZ	F6809ZZ	2RS	2RU	-	6187	5381	11.0	13.0	J
	68	71	0.60	12	2.5	6909	F6909	6909ZZ	F6909ZZ	2RS	2RU	-	14100	10830	9.7	11.0	RJ
50	62	-	0.30	6	-	6710	-	-	-	2RS	-	-	2670	2640	3.5	4.1	W
	65	68	0.30	7	1.5	6810	F6810	6810ZZ	F6810ZZ	2RS	2RU	-	6610	6090	9.6	11.0	J,RJ <sup>(3)</sup>
	72	75	0.60	12	2.5	6910	F6910	6910ZZ	F6910ZZ	2RS	2RU	-	14540	11710	9.0	11.0	RJ
55	72	-	0.30	9	-	6811	-	6811ZZ	-	2RS	2RU	-	8800	8100	8.7	10.0	RJ
	80	-	1.00	13	-	6911	-	6911ZZ	-	2RS	-	-	16600	14100	8.1	9.6	RJ
60	78	-	0.30	10	-	6812	-	6812ZZ	-	2RS	-	-	11500	10600	8.0	9.4	RJ
	85	-	1.00	13	-	6912	-	6912ZZ	-	2RS	-	-	20200	17300	7.5	8.9	RJ
65	85	-	0.60	10	-	6813	-	6813ZZ	-	2RS	-	-	11900	11500	7.3	8.6	RJ
	90	-	1.00	13	-	6913	-	6913ZZ	-	2RS	-	-	17400	16100	7.1	8.4	RJ
70	90	-	0.60	10	-	6814	-	6814ZZ	-	2RS	-	-	12100	11900	6.8	8.1	RJ
	100	-	1.00	16	-	6914	-	6914ZZ	-	2RS	-	-	23700	21200	6.4	7.6	RJ
75	95	-	0.60	10	-	6815	-	6815ZZ	-	2RS	-	-	12500	12900	12.5	12.9	RJ
	105	-	1.00	16	-	6915	-	6915ZZ	-	2RS	-	-	24400	22600	6.1	7.2	RJ
80	100	-	0.60	10	-	6816	-	6816ZZ	-	2RS	2RU	-	12700	13300	12.7	13.3	RJ
	110	-	1.00	16	-	6916	-	6916ZZ	-	2RS	-	-	25000	24000	5.7	6.8	RJ
85	110	-	1.00	13	-	6817	-	6817ZZ	-	2RS	-	-	18700	19000	5.6	6.6	RJ
	120	-	1.10	18	-	6917	-	6917ZZ	-	2RS	-	-	31900	29600	5.3	6.3	RJ
90	115	-	1.00	13	-	6818	-	6818ZZ	-	2RS	-	-	19000	19700	5.3	6.3	RJ
	125	-	1.10	18	-	6918	-	6918ZZ	-	2RS	-	-	32800	31600	5.1	6.0	RJ

Bearings also available with single shield or seal: suffix Z, RS, RU or TS.  
Bearings also available with stainless material: suffix H.

<sup>(3)</sup> Carbon Chrome bearings use RJ type retainer, stainless bearings use J type cage.

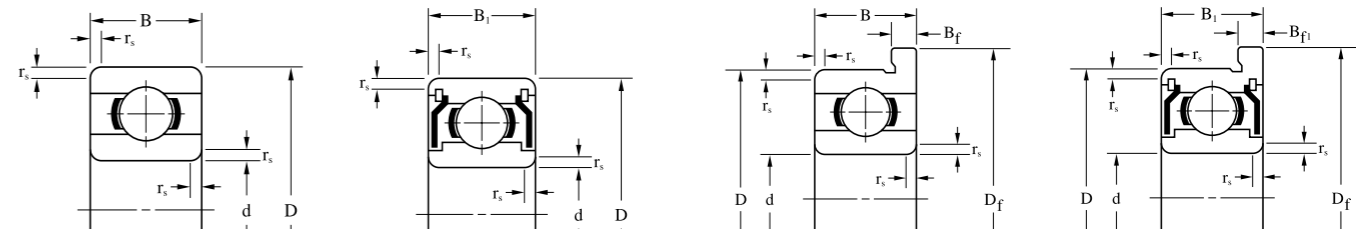

# Large Size Stainless Steel Sizes

## 6000H 6200H 6300H

Bore Diameter d	Outer Diameter D	Width B	Radius r <sub>s</sub> (min)	ABIS Reference		ABIS Reference			Load Rating		Max. Speed		Cage Type
				Open	Shield	Shield			Cr(N)	Cor(N)	Grease	Oil	
mm	mm	mm	mm		ZZ	2RS	2RU	TTS			x1000rpm		
10	26	8	0.3	6000H*	ZZ	2RS	2RU	TTS	3860	1570	31	36	J
	30	9	0.6	6200H*	ZZ	2RS	2RU	-	4340	1920	24	29	RJ,TW
	35	11	0.6	6300H	ZZ	2RS	2RU	-	6870	2750	22	27	RJ
12	28	8	0.3	6001H*	ZZ	2RS	2RU	TTS	4340	1910	27	32	J,TW
	32	10	0.6	6201H	ZZ	2RS	2RU	-	5770	2450	22	27	RJ,TW
	37	12	1.0	6301H	ZZ	2RS	2RU	-	8240	3360	20	25	RJ
15	32	9	0.3	6002H*	ZZ	2RS	2RU	-	4750	2270	23	27	RJ,TW
	35	11	0.6	6202H	ZZ	2RS	2RU	-	6490	3000	20	24	RJ,TW
	42	13	1.0	6302H	ZZ	2RS	2RU	-	9710	4370	17	20	RJ
17	35	10	0.3	6003H	ZZ	2RS	2RU	-	5090	2630	21	25	RJ,TW
	40	12	0.6	6203H	ZZ	2RS	2RU	-	8130	3850	17	21	RJ,TW
	47	14	1.0	6303H	ZZ	2RS	2RU	-	11550	5330	15	18	RJ
20	42	12	0.6	6004H	ZZ	2RS	2RU	-	7960	4050	17	21	RJ,TW
	47	14	1.0	6204H	ZZ	2RS	2RU	-	10910	5360	15	17	RJ,TW
	52	15	1.1	6304H	ZZ	2RS	2RU	-	13490	6310	14	17	RJ
25	47	12	0.6	6005H	ZZ	2RS	2RU	-	8550	4690	15	18	RJ,TW
	52	15	1.0	6205H	ZZ	2RS	2RU	-	11900	7390	13	15	RJ,TW
	62	17	1.1	6305H	ZZ	2RS	2RU	-	17490	9060	11	13	RJ
30	55	13	1.0	6006H	ZZ	2RS	2RU	-	11240	6610	13	15	RJ,TW
	62	16	1.0	6206H	ZZ	2RS	2RU	-	16530	9080	11	13	RJ,TW
	72	19	1.1	6306H	ZZ	2RS	2RU	-	22630	12080	9.6	12	RJ
35	62	14	1.0	6007H	ZZ	2RS	2RU	-	13560	8250	11	13	RJ
	72	17	1.1	6207H	ZZ	2RS	2RU	-	21810	12360	9.2	11	RJ
	80	21	1.5	6307H	ZZ	2RS	2RU	-	28290	15270	8.5	10	RJ
40	68	15	1.0	6008H	ZZ	2RS	2RU	-	14250	9220	10	12	RJ
	80	18	1.1	6208H	ZZ	2RS	2RU	-	24730	14330	8.3	10	RJ
45	75	16	1.0	6009H	ZZ	2RS	2RU	-	15150	9660	9.2	11	RJ
	85	19	1.1	6209H	ZZ	2RS	2RU	-	27790	16300	7.7	9.2	RJ
50	80	16	1.0	6010H	ZZ	2RS	2RU	-	18510	13260	8.4	9.9	RJ
	90	20	1.1	6210H	ZZ	2RS	2RU	-	29800	18610	7.1	8.5	RJ

\*Bearings also available with Carbon Chrome material: without H suffix.  
Bearings also available with single shield or seal: suffix Z, RS, RU or TS.

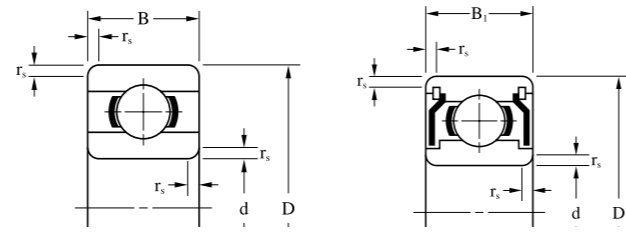

## Extra Thin Sizes

### ET Series - Metric

Bore Diameter d	Outer Diameter D	Open Type Width B	Seal•Shield Type Width B <sub>1</sub>	Radius r <sub>s</sub> (min)	Bearing Reference			Load Rating		Max. Speed		Cage Type
					Open	Shield	Seal	Cr (N)	Cor (N)	Grease	Oil	
mm	mm	mm	mm	mm						x1000rpm		
15	20	3.5	-	0.15	ET2015	-	-	942	582	22	26	W
	21	3.5	-	0.15	ET2115	-	-	939	581	22	26	W
16	22	4.0	-	0.15	ET2216	-	-	968	619	20	24	W
	23	4.5	4.5	0.15	ET2316	ZZS	TTS	968	619	20	24	W
18	24	4.0	-	0.15	ET2418	-	-	988	654	18	21	W
	25	4.0	4.0	0.15	ET2520	ZZS	TTS	1011	691	17	20	W

### ER Series - Inch

0.3750	0.6250	0.1562	0.1562	0.0098	ER1038	ZZS	TTS	856	435	30	35	W
0.5000	0.7500	0.1562	0.1562	0.0098	ER1212	ZZS	TTS	918	542	24	28	W
0.6250	0.8750	0.1562	0.1562	0.0098	ER1458	ZZS	TTS	968	619	20	24	W
0.7500	1.0000	0.1562	0.1562	0.0098	ER1634	ZZS	TTS	1011	691	17	20	W

Bearings also available with single shield or seal: suffix ZS or TS.  
Bearings also available with stainless material: suffix S

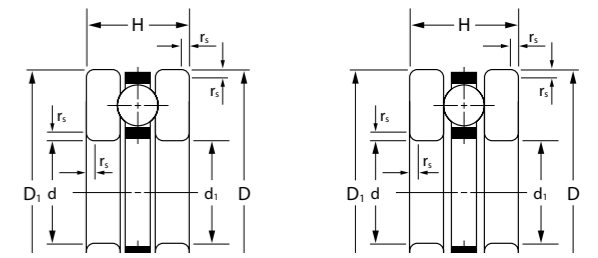

## Thrust Sizes

### FM Series with raceway

Bearing Reference	Inner Ring Bore Dia.	Inner Ring Bore Dia.	Outer Ring Bore Dia.	Inner Ring Bore Dia.	Radius	Height	Load Rating		Max Speed (x1000rpm)		Cage Type
	d	d <sub>1</sub>	D	D <sub>1</sub>	r <sub>s</sub> (min)	H	Ca(N)	Coa(N)	Grease	Oil	
	mm	mm	mm	mm	mm	mm					
F3-8M	3	3.2	8	7.8	0.15	3.5	993	590	19	28	TP
F4-9M	4	4.2	9	8.8	0.15	4.0	944	640	17	25	TP
F4-10M	4	4.2	10	9.8	0.15	4.0	925	661	16	24	TP
F5-12M	5	5.2	12	11.8	0.20	4.0	1056	942	14	22	TP
F6-12M	6	6.2	12	11.8	0.20	4.5	1819	1588	14	20	TP
F6-14M	6	6.25	14	13.8	0.20	5.0	2155	1701	12	18	TP
F7-13M	7	7.2	13	16.8	0.20	4.5	1767	1645	13	20	TP
F7-17M	7	7.2	17	16.8	0.30	6.0	3086	2675	10	15	TP
F8-16M	8	8.2	16	15.8	0.30	5.0	3917	3394	11	17	TP
F8-19M	8	8.2	19	18.8	0.30	7.0	3939	3476	9	13	TP
F9-20M	9	9.2	20	19.8	0.30	7.0	3855	3571	8	13	TP
F10-18M	10	10.2	18	17.8	0.30	5.5	2470	2721	10	15	TP

### F Series without raceway

Bearing Reference	Inner Ring Bore Dia.	Inner Ring Bore Dia.	Outer Ring Bore Dia.	Inner Ring Bore Dia.	Radius	Height	Load Rating		Cage Type
	d	d <sub>1</sub>	D	D <sub>1</sub>	r <sub>s</sub> (min)	H	Ca(N)	Coa(N)	
	mm	mm	mm	mm	mm	mm			
F2-6	2.0	2.0	6	6	0.10	3.0	117	83	TD
F2X-7	2.5	2.5	7	7	0.10	3.5	156	117	TD
F3-8	3.0	3.0	8	8	0.10	3.5	166	137	TD
F4-9	4.0	4.0	9	9	0.15	4.0	166	156	TD
F4-10	4.0	4.0	10	10	0.15	4.5	274	245	TD
F5-11	5.0	5.0	11	11	0.15	4.5	284	284	TD
F6-12	6.0	6.0	12	12	0.15	4.5	274	284	TD
F7-15	7.0	7.0	15	15	0.20	5.0	558	548	TD
F8-16	8.0	8.0	16	16	0.20	5.0	597	627	TD
F9-17	9.0	9.0	17	17	0.20	5.0	437	542	TD
F10-18*	10.0	10.0	18	18	0.20	5.5	617	705	TD

\*Also available in stainless steel.

# Technical Data

## Bearing Materials

The standard material for ABIS rings and balls is a vacuum degassed high carbon chromium steel allowing for high efficiency, low torque, low noise level and long bearing life. For bearings requiring anti-corrosion or heat-resistant properties, martensitic stainless steel is used.

Material	Sizes	Designation	Symbol	Chemical Composition (Wt%)						
				C	Si	Mn	P	S	Cr	Mo
Chromium Steel	All	SUJ2 SAE 52100 100Cr6	-	0.95-1.10	0.15-0.35	≤0.50	≤0.025	≤0.025	1.30-1.60	≤0.08
Stainless Steel	d ≤ 25 mm & D ≤ 52 mm	KS440 (ACD34), X65Cr6	S, H	0.95-1.20	≤1.00	≤1.00	≤0.040	≤0.030	16.0-18.0	≤0.75
	d > 25 mm & D ≤ 52 mm	SUS440C, AIS1440C, X102CrMo17	S, H	0.60-0.75	≤1.00	≤1.00	≤0.030	≤0.020	11.5-13.0	≤0.030

## Noise Testing

Bearing acoustical noise is a function of both the bearing itself and the way in which it is used. Bearings can be specified as 100% noise-tested during manufacture. Bearing noise is not generally influenced by ABEC precision, but rather by manufacturers' internal quality standards, particularly raceway finish. There are no fixed reference standards among manufacturers for noise testing.

The standard instrument used for bearing noise testing is the Anderson Meter (sometimes called Anderometer) made by Sugawara Laboratories. This measures noise with an accelerometer contacting the outer race of the bearing while the inner race is rotated at 1,800 RPM. Noise levels are separated into 3 bands, designated as follows:

**High band 1,800 - 10,000 Hz      Medium band 300 - 1,800 Hz      Low band 50 - 300 Hz**





According to the type of bearing (material and noise grade), a different attenuation is used for each band. Meters are calibrated in Andersons. Standard testing procedure requires that bearings are washed clean of any lubricant and 2 drops of fresh MIL-L-6085A oil lubricant added prior to testing.

Typical attenuation values for each band are given in the table below, according to bearing material and noise grade. A "pass" for any bearing grade is defined as < 40% of full scale on the Anderson meters for each brand. In this case, this translates to pass levels of Low < 6.4, Med < 2.4, High < 3.2.

Anderson Meter Attenuation Settings				
Material	Noise Rating	Low Band	Mid Band	High Band
5100 Chrome Steel	Standard	16	6	8
	EMQ	16	6	8
	EMQ2	12	6	8
440C/Martensitic Stainless	Standard	16	10	24
	EMQ	16	10	24
	EMQ2	16	8	10

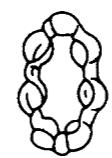
**Anderson Meter < 40% = Good Bearing**

## Cages

				
<b>W One-Piece Steel Crown Type</b>	<b>J Two-piece Steel Ribbon Type</b>	<b>RJ Two-pieces Steel Rivet Type</b>	<b>TW One-piece Nylon Crown Type</b>	<b>Full Complement of Balls</b>
The stainless steel pressed cage is inner ring guided. It shows excellent performance in low torque, low speed applications.	Consists of two mating steel pressings, the cover side and the finger side. Usually guided by the rolling elements and designed to reduce frictional torque.	The RJ type cage is suitable for larger bearings with a high load carrying capacity. The two pieces are riveted together and are strong enough to withstand higher levels of vibration and acceleration. The cage is guided by the balls and reduces frictional torque.	Moulded nylon cage. Reduces the fluctuation in running torque. Suitable for high speeds. Guided by the rolling elements. NYLON CAGE operating temperature range: from -30 to +120°C	This type of bearing has no cage but maximum possible number of balls. Due to the fact that the inner and outer ring have a filling slot, the axial load carrying capacity of this bearing type is low. This type of bearing is suitable for high radial load, low speed applications.

## Closures

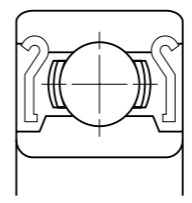
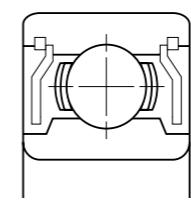
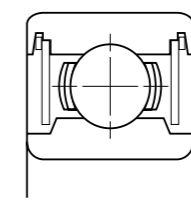
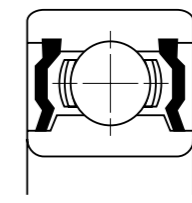
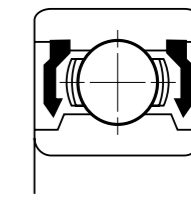
				
<b>ZZ Pressed Steel Shield</b>	<b>ZZS Steel Shield with Snap Ring</b>	<b>TTS Teflon Seal with Snap Ring</b>	<b>2RS Contact Rubber Seal</b>	<b>2RS Non-Contact Rubber Seal</b>
Non-contact shield pressed into outer ring. Very little grease leakage and low ingress of contaminants.	Non-contact shield fixed with snap ring into outer ring. Very little grease leakage and low ingress of contaminants.	Teflon seal reinforced with glass fibre is retained in outer ring by snap ring. Low ingress of contaminants. Mainly used for smaller or narrower bearings. Seal can flex to accommodate internal pressure changes. TEFLON SEAL operating temperature range: from -100 to +260°C	Rubber seal fitted into outer ring. Light contact with inner ring, retains grease and prevents ingress of external contaminants. NBR SEAL operating temperature range: from -40 to +120°C FKM(VITON) SEAL operating temperature range: from -30 to +230°C	Non-contact rubber seal fitted into outer ring, still provides effective sealing. NBR SEAL operating temperature range: from -40 to +120°C FKM(VITON) SEAL operating temperature range: from -50 to +230°C

## Technical Data

### Radial Play

The radial play of a bearing has considerable influence on its performance. Therefore consideration must be given to the speed, temperature, load, adjacent materials (different coefficients of expansion) and fitting conditions associated with each individual application when selecting the appropriate group. The following notes are given for guidance against the various groups detailed in the table below:

Radial Play											Remarks		
Service Requirements	Miniature Bearings			Standard Metric Bearings									
	I/D	<10		10 only	10+ -18	18+ -24	24+ -30	30+ -40	40+ -50			REF	
		0.001mm	0.0001"	REF	0.001mm								
Small bearing clearance required axially without the use of preload shims or springs. Low torque not the prime requirement. High thrust loads will not occur.	TIGHT	0-5	0-2	MC1	0-7	0-9	0-10	1-11	1-11	1-11	C2	Interference fits must be avoided. Beware differential expansion. Careful attention should be paid to any excessive temperature rise in service.	
		3-8	1-3	MC2									
Moderate torque acceptable. Moderate thrust loads may occur.	MEDIUM	5-10	2-4	MC3 (std)	2-13	3-18	5-20	5-20	6-20	6-23	CN (CO) std		Interference fits are not recommended.
		8-13	3-5	MC4	8-23	11-25	13-28	13-28	15-33	18-36	C3		
Minimal torque required. or High thrust load capability.	LOOSE	13-20	5-8	MC5	14-29	18-33	20-36	23-41	28-46	30-51	C4	Moderate interference fits can be applied. Axial play may required to be controlled by shims or springs.	
		20-28	8-11	MC6	20-37	25-45	28-48	30-53	40-64	45-73	C5		

### Internal Clearance

This is generally referred to as radial play although it also incorporates axial play as well because it is actually the amount of space between the rolling elements of the bearing, namely inner ring, outer ring and balls.

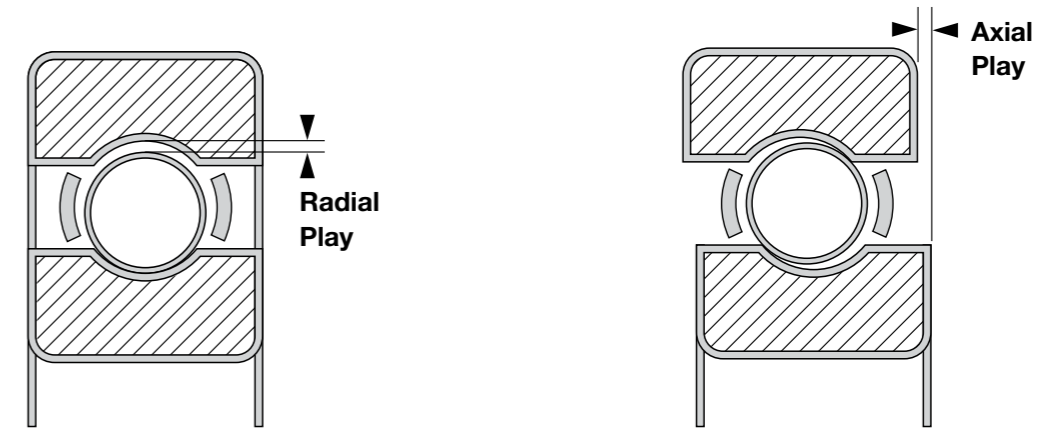

**Radial Play** - is clearance perpendicular to the axis of the bearing and better described as the movement available to the outer ring when inner is fixed. This can be more accurately defined as follows: average diameter outer ring raceway minus average diameter of inner ring minus x2 ball diameter.

**Axial Play** - is the opposite of radial play as it is the movement of the rings relative to each other along the axis of the bearing. The amount of axial play is controlled by the bearing raceway curvature but as a general rule is around x10 the value of radial play.

Radial play is a major consideration when selecting a bearing. Prior to fitting a bearing has an 'initial' amount of play and after being mounted it has a 'residual' radial play (sometimes referred to as operational radial play as it is what is remaining). When a shaft is supported between bearings then consideration needs to be given to the alignment of the bearings as misalignment reduces radial play, therefore it is important that selection accounts for this. There should always be some 'residual' radial play after fitting as this extends bearing life by avoiding skidding and reducing axial play.

There are a number of things that can change radial play during fitting. A tight shaft, larger than the inner ring, will expand the inner ring and this can reduce radial play up to 80% of the interference fit. The same thing happens if the outer ring is larger than the housing diameter, the ring is effectively compressed and reduces radial play in the same way. If there was a temperature difference seen between the shaft and the housing then thermal expansion either on the inner or outer ring, would lead to a reduction in radial play. This may be calculated as opposite:

**Chrome Steel** -  $0.0000125 \times (\text{inner ring temp} - \text{outer ring temp } ^\circ\text{C}) \times \text{outer ring raceway diameter in mm}$ .

**440 Stainless Steel** -  $0.0000103 \times (\text{inner ring temp} - \text{outer ring temp } ^\circ\text{C}) \times \text{outer ring raceway diameter in mm}$ .

The outer ring raceway diameter is roughly calculated as:  $0.2 \times (d + 4D)$  where **d** is the bore in mm and **D** is the outer diameter in mm.

Another factor to consider relating to thermal expansion is the material that is used for the shaft and housing. For example, a housing material with a higher coefficient of expansion than the bearing material could under certain conditions 'squeeze' the bearing outer ring and reduce radial play.

# Technical Data

## Lubricants

### Lubricating Oil and Grease

	Lubricating Oil	Lubricating Grease
Rotating Speed	Low • Medium • High Speed	Low • Medium Speed
Lubricant Efficiency	Excellent	Good
Cooling Effect	Good	None
Torque	Comparatively Low	Comparatively High
Lubricant Life	Long	Comparatively Short
Lubricant Replacement	Easy	Difficult
Lubricant Leakage	Should not be used where oil leakage is unacceptable	Little Grease Leakage
Impurities Filtration	Easy	Difficult
Sealing Equipment	Complex	Simple

### Grease Filling Volume

Symbol	Filling Volume (%)	Operating Condition	
		Speed	Load
M	70±10	Low	Heavy
S	50±10	Low	Medium
G	40±10	Medium	Medium
<b>L Default Standard</b>	<b>30±10</b>	<b>Medium</b>	<b>Medium</b>
Q	25±5	Medium	Medium
K	20±5	High	Light
X	10±5	High	Light

Note: Light load ( $\leq 0.06Cr$ )  
Standard load ( $\leq 0.12Cr$ )

### Criteria for Lubricating Oil Selection

Operating Temperature of Bearing (°C)	dn	ISO Viscosity Grade Lubricating Oil (VG)	
		Medium Load	Heavy Load/Shock Load
-30~0	Up to permissible rotating speed	15, 22, 32	32, 46
0~+60	Up to 15000	32, 46, 68	100
	15000 ~ 80000	32, 46	68
	80000 ~ 150000	22, 32	32
	150000 ~ 500000	10	22, 32
+60~+100	Up to 15000	150	220
	15000 ~ 80000	100	150
	80000 ~ 150000	68	100, 150
	150000 ~ 500000	32	68
+100~+150	Up to permissible rotating speed	320	

Note: 1. If heavy loads occur at low speeds, a higher viscosity lubricating oil should be used.  
2. This table is for oil bath lubrication system and recirculating oil systems.  
3. dn = Bearing bore diameter d (mm) x rotating speed n (r.p.m)

### Common Oil Brands

Code	Brand	Lubricant Base	Viscosity (m <sup>2</sup> /s)	Operating Temperature (°C)	Approved Standard	Comments
AF2*	Aero Shell Fluid 12	Diester	8.9 (54.4°C)	-50~+205	MIL-PRF-6085D	Low viscosity, wide temperature range and high operating temperature. Good general purpose oil for instrument/aircraft applications
AF3	Aero Shell Fluid 3	Mineral	10.0 (38°C)	-47~+115	MIL-PRF-7870C	Low viscosity, good general purpose oil for instrument/aircraft applications
KAZ	Krytox 143AZ	Fluorinated	12.4 (40°C)	-54~+149	-	Inert, high temperature capacity suitable for low speed/load. Impervious plastics/elastomers
PD8	Isoflex PDP38	Diester	12.0 (40°C)	-55~+100	-	Low viscosity, good general purpose oil for instrument/aircraft applications

### Common Grease Brands\*\*

Code	Brand	Thickening Agent	Lubricant Base	Operating Temperature (°C)	Approved Standard	Comments
SRL*	Multemp SRL	Lithium	Diester, Mineral	-50~+150	-	Good temperature range, load capacity and water resistance
AV2	Alvania 2S	Lithium	Mineral	-25~+120	-	Good temperature range, load capacity and water resistance
AG7	Aero Shell NO.7	Microgel	Diester	-73~+149	MIL-PRF-83282D	Good temperature range, load capacity and water resistance
AG2	Aero Shell NO.22	Microgel	Synthetic Hydrocarbon	-65~+204	MIL-PRF-81322F	Good temperature range, high load/speed capacity and good water resistance
A3S	Aero Shell NO.33MS	Lithium	Synthetic Hydrocarbon Ester	-73~+121	MIL-G-21164D	Low temperature, high load capacity and good water resistance
PS2	Multemp PS NO.2	Lithium	Diester, Mineral	-55~+130	-	Good temperature range, load capacity and water resistance
SL8	Isoflex Super LDS18	Lithium	Diester	-60~+130	MIL-G-7118-A	Good temperature range, load capacity and water resistance
K24	Krytox 240AC	PFPE	Fluorinated	-35~+238	MIL-G-27617	Suitable for high temperature applications. High viscosity at room temperature
B32	Beacon 325	Lithium	Diester	-60~+120	-	Suitable for low torque/quiet running applications

\* Default lubricant and will be supplied unless otherwise specified.

\*\* If you have a specific requirement for another oil or grease please contact us for advice.





## Technical Data

### Importance of correct fitting of bearings

A bearing can only perform to its full capacity when it is correctly fitted on the shaft and in the housing. Insufficient interference on fitting surfaces could cause bearing rings to creep in a circumferential direction. Once this happens, considerable wear occurs on the fitting surface and both shaft and housing can be damaged. Furthermore, abrasive particles may enter the bearing causing vibration, excessive heat and damage to raceways. It is therefore necessary to provide bearing rings under rotating load with an adequate interference fit to prevent creep. When using thin-type bearings under low load, the bearings should be fastened by a nut. Statically loaded bearings generally do not need to be fitted with an interference fit. Only when subject to a high degree of vibration do both inner and outer rings require fitting with an interference fit.

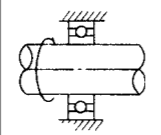
Fitting of Bearing & Shaft				
Condition (Steel Shaft)		Shaft Bore Diameter	Shaft Tolerance Class	
			Thin-Type	Others
Inner Ring Rotating Load or Indeterminate Load Direction	Light Load $\leq 0.06C$ or Fluctuating Load	10 $\leq d \leq 18$ 18 $\leq d \leq 30$ 30 $\leq d \leq 50$	h5 h5 h5	js5 js5 js5
	Standard Load = 0.06 ~ 0.11C	10 $\leq d \leq 18$ 18 $\leq d \leq 30$ 30 $\leq d \leq 50$	js5 js5 js5	j5 k5 k5
Outer Ring Rotating Load	Necessary for Inner Ring Turning Easily Around Shaft	All Bore Diameters	g6	g6
	Unnecessary for Inner Ring Turning Easily Around Shaft	All Bore Diameters	h6	h6

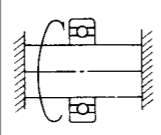
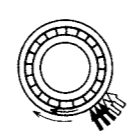
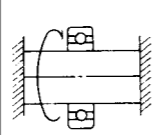
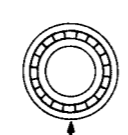
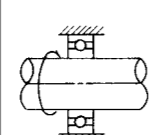
Fitting of Bearing & Housing				
Condition (One-Piece Housing)		Axial Directional Movement of Outer Ring	Tolerance Class of Housing Seats	
			Thin-Type	Others
Inner Ring Rotating Load	Varying Loads	Easy to move	H7	H7
	Light or Standard Loads	Easy to move	H8	H8
	High Temperature of Inner Ring and Shaft	Easy to move	G7	G7
	Light or Standard Load Precise Rotation Quiet Operation	As a rule, impossible to move Possible to move Easy to move	K6 JS6 H6	K6 J6 H6
Indeterminate Load Direction	Light or Standard Load	In general, possible to move	JS7	J7
	Standard or Heavy Load	As a rule, impossible to move	K7	K7
	Large Shock Load	Impossible to move	M7	M7
	Light or Fluctuating Load	Impossible to move	M7	M7
Outer Ring Rotating Load	Standard or Heavy Load	Impossible to move	N7	N7
	Thin-Type Housing Seats Heavy or Large Shock Load	Impossible to move	P7	P7

Characteristics of Load & Fitting			
Rotating Ring	Load	Load Condition	Fitting
 Inner Ring	 Static	Inner Ring Rotating Load Outer Ring Static Load	Interference Fit for Inner Ring Clearance Fit for Outer Ring
 Outer Ring	 Rotating		
 Outer Ring	 Static	Outer Ring Rotating Load Inner Ring Static Load	Clearance Fit for Inner Ring Interference Fit for Outer Ring
 Inner Ring	 Rotating		
In case of fluctuating load direction or unbalanced load	Rotating or Static	Indeterminate Load Direction	Interference Fit for Inner and Outer Ring

### Faults, Causes & Remedies

	Problem	Cause	Remedy
Noise	<b>High pitched metallic noise</b>	Poor lubrication Clearance too small Poor fitting Excessive load	Improve lubrication Correct clearance Investigate mounting method and seating Examine shaft and housing tolerances for closing effect
	<b>Low pitched metallic noise</b>	Brinelled raceway surface	Avoid shock loads
	<b>Regular noise</b>	Rust and damage Flaking of raceway surface	Check and replace seals and relubricate Improve lubrication and check fitting, clearance and fixing method
	<b>Irregular noise</b>	Ingress of foreign matter Excessive clearance Damage and flaking of rolling element	Check and replace seals and relubricate Correct clearance Reduce loads and/or clearance
	<b>Variable noise</b>	Variable clearance due to temperature changes Damage to raceways	Check fits taking housing materials and temperature into consideration Improve lubrication and check fitting, clearance and fixing method
	<b>Heavy vibration</b>	Flaking of raceway and rolling element Ingress of foreign matter Excessive clearance Poor location	Improve lubrication and check fitting, clearance and fixing method Check and replace seals and relubricate Correct clearance Ensure abutment face and fitting diameter are perpendicular
	<b>Excessive heat generation</b>	Clearance too small Poor location Excessive load Poor lubrication Creep	Correct clearance Ensure abutment face and fitting diameter are perpendicular Examine shaft and housing tolerances for closing effect Improve lubrication Maintain recommended shaft and housing fits
	<b>Lubrication failure</b>	Too much grease Ingress of foreign matter	Use the correct lubricant quantity Check and replace seals and relubricate

# Technical Data

## Tolerances

For inch bearings tolerances are based on Section 3 of the AFBMA Standards for ABEC Class1 and Section 12 for ABEC Class 3. Refer to Table 1.

For metric series bearings up to 9 mm outer diameter tolerances are based on AFBMA Standards as above. For diameters over 9 mm they are based on ISO R492-R1648 tolerances Class P0, P6 and P5. Refer to Tables 1 & 2.

N.B. Thin section bearings, Series E only, are available in tolerance Class P5.

**Table 1 - Bearings with Bore sizes 0-0.375 inches, 0-18 mm. Outside diameters 0-30 mm.**

ABEC						ISO					
Unit 0.0001"						Unit 0.001mm					
Class 1		Class 3		Class 5		Class 0		Class 6		Class 5	
High	Low	High	Low	High	Low	High	Low	High	Low	High	Low
0	-3	0	-3	0	-2	<b>Inner Ring Diameter</b>					
Mean value of bore dm						0	-8	0	-7	0	-5
Absolute value of bore d						+2	-10	+1	-8	0	-5
Radial run out (max.)						10		6		5	
Width B						0	-120	0	-120	0	-25
Width variation (max.)						12		15			5
<b>Outer Ring Diameter</b>											
Mean value of O D (Open) Dm						0	-8	0	-7	0	-5
Absolute value of O D (Open) D						+2	-10	+1	-8	0	-5
Absolute value of O D (Closed) D											
Radial run out (max.)						15		8		5	
Width B						0	-120	0	-120	0	-25
Flange dia D <sub>f</sub>						+125	-50 <sup>(1)</sup>	+125	-50 <sup>(1)</sup>		
Flange width B <sub>f</sub>						0	-50 <sup>(1)</sup>	0	-50 <sup>(1)</sup>		

<sup>(1)</sup> Manufacturers tolerances

**Table 2 - Bearings with Bore sizes 20-45mm. Outside diameters 31-80 mm.**

Parameters	ISO											
	Unit 0.001mm											
	Class 0				Class 6				Class 5			
Inner Ring Diameter	20-30		35-45		20-30		35-45		20-30		35-45	
	High	Low	High	Low	High	Low	High	Low	High	Low	High	Low
Mean value of bore dm	0	-10	0	12	0	-8	0	-10	0	-6	0	-8
Absolute value of bore d	+3	-13	+3	-15	+1	-9	+1	-11	0	-6	0	-8
Radial run out (max.)	13		15		8		10		4		5	
Width B	0	-120	0	120	0	-120	0	-120	0	-120	0	-120
Width variation (max.)	20		20		20		20		5		5	
Outer Ring Diameter	32-50		52-80		32-50		52-80		32-50		52-80	
	High	Low	High	Low	High	Low	High	Low	High	Low	High	Low
Mean value of O D (Open) Dm	0	-11	0	-13	0	-9	0	-11	0	-7	0	-9
Absolute value of O D (Open) D	+3	-14	+4	-17	+2	-11	+2	-13	0	-7	0	-9
Absolute value of O D (Closed) D	+7	-18	+10	-23	+6	-15	+7	-18				
Radial run out (max.)	20		25		10		13		7		8	
Width B	0	-120	0	-120	0	-120	0	-120	0	-120	0	-120

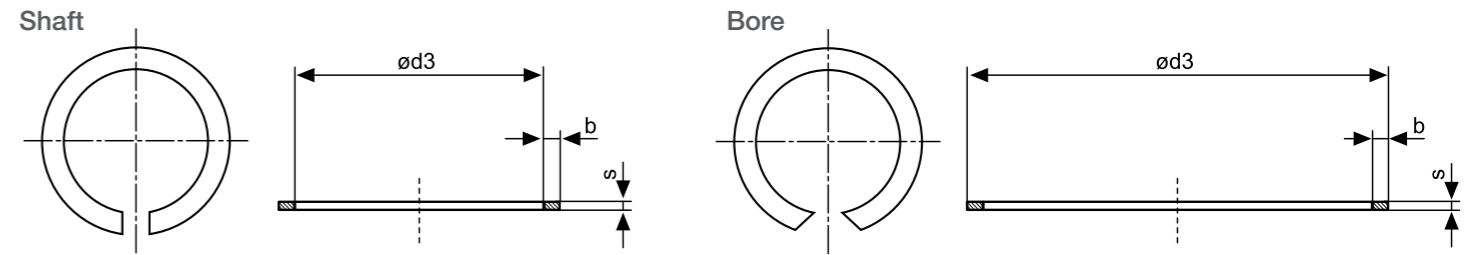

# Retaining Rings

## Shaft

Reference	Dimensions (mm)					
	Shaft	Retaining Ring			Groove	
	d1 Ø	d3 max.	b ± 0.10	s ± 0.02	d 2 + 0.05	m + 0.03
WSR 3	3	2.60	0.50	0.30	2.70	0.33
WSR 4	4	3.60	0.50	0.30	3.70	0.33
WSR 5	5	4.50	0.70	0.40	4.60	0.44
WSR 6	6	5.45	0.70	0.40	5.60	0.44
WSR 7	7	6.45	0.70	0.40	6.60	0.44
WSR 8	8	7.35	0.90	0.50	7.50	0.55
WSR 9	9	8.30	0.90	0.50	8.50	0.55
WSR 10	10	9.25	0.90	0.50	9.50	0.55

Material: Spring Steel 1.4310/AISI 301

## Bore

Reference	Dimensions (mm)					
	Bore	Retaining Ring			Groove	
	d1 Ø	d3 max.	b ± 0.10	s ± 0.02	d 2 + 0.05	m + 0.03
BSR 4	4	4.40	0.50	0.30	4.30	0.33
BSR 5	5	5.45	0.50	0.30	5.30	0.33
BSR 6	6	6.45	0.50	0.30	6.30	0.33
BSR 7	7	7.50	0.50	0.30	7.30	0.33
BSR 8	8	8.60	0.70	0.40	8.40	0.44
BSR 9	9	9.60	0.70	0.40	9.40	0.44
BSR 10	10	10.65	0.70	0.40	10.40	0.44
BSR 11	11	11.65	0.70	0.40	11.40	0.44
BSR 12	12	12.75	0.90	0.50	12.50	0.55
BSR 13	13	13.75	0.90	0.50	13.50	0.55
BSR 14	14	14.80	0.90	0.50	14.50	0.55
BSR 15	15	15.80	0.90	0.50	15.50	0.55
BSR 16	16	16.85	0.90	0.50	16.50	0.55
BSR 17	17	17.85	0.90	0.50	17.50	0.55
BSR 19	19	20.00	1.10	0.60	19.60	0.66

Material: Spring Steel 1.4310/AISI 301





# Shims & Spring Washers

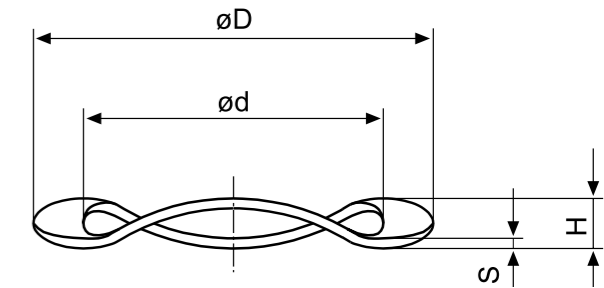
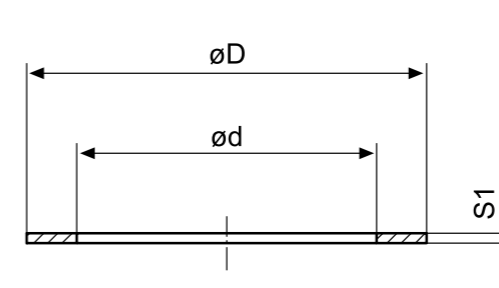

Dimensions (mm)					Used for	
Shims		Spring Washers			Used for	
d x D Reference	S1	d x D Reference	H	S	On Shaft	On Housing
AS 1.55 x 2.50	0.15	-	-	-	68/1.5; 69/1.5	-
	-	WF 1.60 x 2.90	0.40	0.06	-	-
	-	WF 1.90 x 2.80	0.50	0.08	-	-
AS 2.00 x 4.30	0.10	-	-	-	-	-
	0.16					
	0.20					
AS 2.25 X 3.20	0.08	WF 2.15 X 3.10	0.50	0.08	682; 692; 5/64	1016
	0.10					
AS 2.80 X3.90	0.08	WF 2.70 X 3.80	0.50	0.08	60/2.2; 68/2.5; 69/2.5; 3/32	68/1.5; 691; 1191
	0.10					
AS 3.05 x 4.50	0.10	-	-	-	-	-
	0.16					
	0.20					
AS 3.30 X 4.40	0.08	WF 3.20 X 4.30	0.50	0.10	623; 683; 693; 1/8A;1/8B; 3175; 1/8A/6; 1/8B/083	-
	0.10					
	0.12					
AS 3.50 X 5.00	0.08	-	-	-	-	-
AS 3.80 x 4.90	0.08	WF 3.70 x 4.80	0.55	0.10	-	682; 69/1.5
	0.10					
	0.12					
AS 4.05 X 5.50	0.10	-	-	-	-	-
	0.20					
AS 4.30 X 5.85	0.10	WF 4.20 X 5.75	0.65	0.12	604; 624; 634; 684; 694; 3967	68/2.5; 692
	0.12					
	0.15					
AS 4.90 X 6.20	0.10	WF 4.80 X 6.10	0.60	0.12	3/16; 4763A; 47638	5/64; 3175
	0.12					
	0.15					
AS 5.20 X 6.75	0.15	-	-	-	-	-
AS 5.30 X 6.85	0.10	WF 5.20 X 6.75	0.65	0.12	625; 635; 685; 695	683; 69/2.5
	0.12					
	0.15					
AS 5.50 X 8.50	0.40	-	-	-	-	-
AS 6.30 X 7.85	0.12	WF 6.20 X 7.75	0.70	0.15	626; 686; 696	60/2.5; 693; 3/32; 1/8A; 3967; 4763A
	0.15					
	0.18					

Dimensions (mm)					Used for	
Shims		Spring Washers			Used for	
d x D Reference	S1	d x D Reference	H	S	On Shaft	On Housing
AS 6.70 X 9.40	0.10	-	-	-	-	-
AS 7.30 X 8.80	0.12	WF 7.20 X 8.70	0.90	0.15	607; 627; 687; 697;	684
	0.15					
	0.18					
-	-	WF 7.20 X 12.0	1.55	0.13	607; 627	63508; 7938; 1/8B/083
AS 8.30 X 9.80	0.10	WF 8.20 X 9.70	0.85	0.18	608; 688; 698; 7938	623
	0.15					
	0.18					
	0.20					
AS 9.30 X 10.80	0.15	WF 9.20 X 10.70	1.15	0.18	609; 629; 689; 699;	685; 694;
	0.18					
	0.20					
AS 10.30 X 11.80	0.18	WF 10.20 X 11.70	1.05	0.20	6000; 6800; 6900; 3/8	604
	0.20					
	0.22					
-	-	WF 10.50 X 15.80*	1.85	0.25	6000	625; 634
AS 11.30 X 12.80	0.18	WF 11.20 X 12.70	1.30	0.20	-	624; 686; 695
	0.20					
	0.22					
	0.25					
AS 12.30 X 13.80	0.20	WF 12.20 X 13.70	1.30	0.22	-	687
	0.22					
	0.25					
AS 13.30 X 14.80	0.20	WF 13.20 X 14.70	1.30	0.22	-	696
	0.22					
	0.25					
	0.30					
AS 14.35 X 15.80	0.22	WF 14.20 X 15.65	1.55	0.25	-	625; 634; 688; 1/4A
	0.25					
	0.30					
AS 15.35 X 16.80	0.22	WF 15.20 X 16.65	1.55	0.25	-	689; 697
	0.25					
	0.30					
AS 16.00 X 22.00	0.10	WF 15.80 X 21.80	1.60	0.20	-	3/8
AS 16.40 X 18.80	0.25	WF 16.20 X 18.55	2.15	0.30	-	607; 626; 635; 6800; 698; 1/4
	0.30					
	0.35					

Material: Spring Steel 1.4310/AISI 301.



## Preload Springs

Preloading of bearings is a process of applying an axial load to either the inner or outer ring of the bearing so that radial play is taken up and running components are in contact. This is seen as good practice as it reduces noise, vibration and ultimately extends bearing life.

There are essentially two methods to preload a bearing. Firstly, a solid preload such as a threaded plug or circlip, or secondly by a spring, i.e. a disc spring. The disadvantage of a solid preload is that it cannot compensate for tolerance build up or thermal movement of the surrounding components and so running torque may be affected.

The disc spring, as well as applying a constant load around the bearing ring, overcomes the disadvantages of using a solid preload. Where a very light preload is required the disc spring has radial slots to reduce the axial force applied.

### Preloading Outer Race

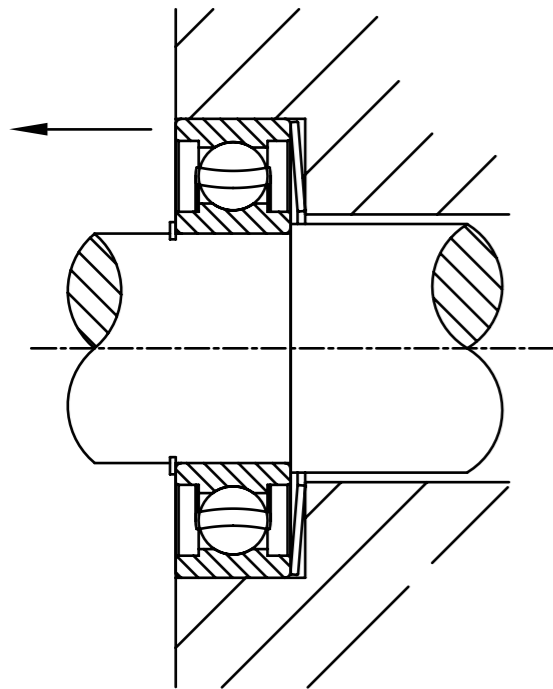

### Preloading Inner Race

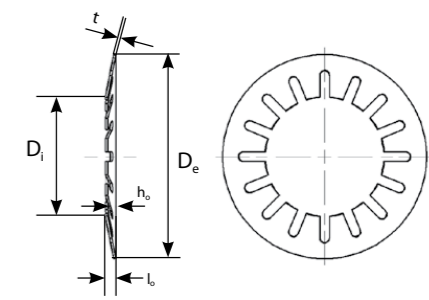
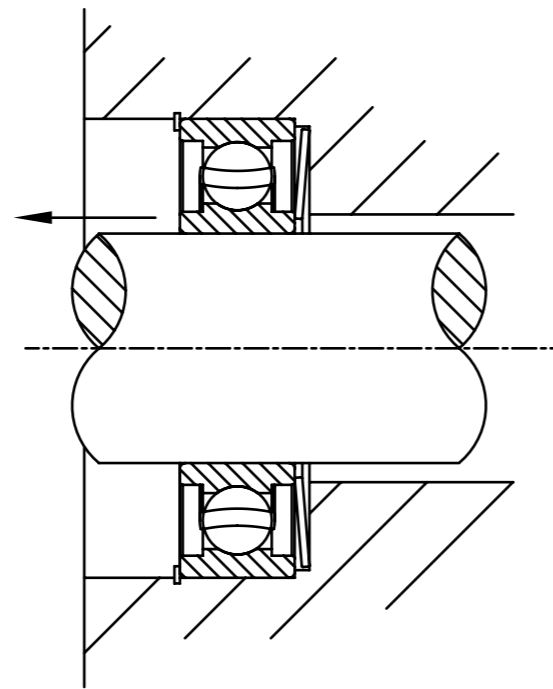

## Preload Springs - Slotted

### Diameter 9.8 - 94.50 mm

Reference	Dimensions						Spring travel s and force F		Weight Per 1000 pieces (kg)	Ball bearing type	Ball bearing dimensions		
	D <sub>e</sub> (mm)	D <sub>i</sub> (mm)	t (mm)	l <sub>o</sub> (mm)	h <sub>o</sub> (mm)	h <sub>o</sub> /t	at s = 0.75 h <sub>o</sub> s (mm)	f (N)			External dia (mm)	Internal dia (mm)	
241 150	9.80	6.20	0.15	0.60	0.45	1.00	0.35	13	0.050	623 EL3	10	3	
241 350	12.80	7.20	0.20	0.65	0.45	0.92	0.35	18	0.130	624 EL4	13	4	
241 650	15.80	8.20	0.25	0.75	0.50	0.74	0.40	20	0.280	625 EL5 634 R4	16	5 4	
241 675	18.80	9.20	0.25	1.00	0.75	0.97	0.55	20	0.440	626 EL6 635 R5	16	6 5	
241 750	18.80	10.20	0.25	1.05	0.80	1.15	0.60	24	0.320	607 EL7	19	7	
241 850	21.80	12.30	0.25	1.25	1.00	1.47	0.75	24	0.420	608 EL8 627 R7	22	8 7	
242 050	23.70	14.30	0.30	1.30	1.00	1.21	0.75	25	0.660	609 EL9	24	9	
242 150	25.70	14.30	0.30	1.40	1.10	1.19	0.80	28	0.700	6000 629 R9	26	10 9	
242 250	27.70	17.30	0.35	1.45	1.10	1.03	0.80	31	0.984	6001	28	12	
242 450	29.70	17.30	0.35	1.55	1.20	1.30	0.90	32	1.200	6200	30	10	
242 550	31.70	20.40	0.35	1.55	1.20	1.30	0.90	33	1.270	6002 6201	32	15 12	
242 750	34.60	20.40	0.40	1.65	1.25	1.10	1.00	32	1.650	6300	35	10	
242 850	34.60	22.40	0.35	1.55	1.20	1.18	0.90	32	1.50	6003 6202	35	17 15	
242 950	36.60	20.40	0.40	1.90	1.50	1.44	1.10	35	2.280	6301	37	12	
243 050	39.60	25.50	0.40	1.90	1.50	1.22	1.10	37	1.920	6203	40	17	
243 150	41.60	25.50	0.45	2.05	1.60	1.13	1.20	39	2.500	6004 6302	42	20 15	
243 250	46.50	30.50	0.45	2.05	1.60	1.11	1.20	44	2.840	6005 6204 6303	47	25 20 17	
243 350	51.50	35.50	0.45	2.10	1.65	1.26	1.25	47	3.070	6205 6304	52	25 20	
243 450	54.50	40.50	0.45	2.15	1.70	1.75	1.30	53	3.200	6006	55	30	
243 550	61.50	40.50	0.55	2.55	2.00	1.21	1.50	54	6.050	6007 6206 6305	62	35 30 25	
243 650	67.50	50.50	0.55	2.60	2.05	1.36	1.60	78	5.500	6008	68	40	
243 750	71.50	45.50	0.60	2.90	2.30	1.47	1.70	74	9.600	6306	72	30	
243 850	71.50	50.50	0.60	2.90	2.30	1.83	1.70	127	8.200	6207	72	35	
243 950	74.50	55.50	0.60	2.90	2.30	1.31	1.70	91	7.580	6009	75	45	
244 125	79.50	50.50	0.70	3.10	2.40	1.36	1.80	83	16.260	6307	80	35	
244 150	79.50	55.50	0.70	2.90	2.20	1.51	1.65	127	14.500	6010 6208	80	50 40	
244 250	84.50	60.50	0.75	3.15	2.40	0.87	1.80	78	13.000	6209	85	45	
244 350	89.50	60.50	0.80	3.30	2.50	1.08	1.90	104	18.100	6308	90	40	
244 450	89.50	65.50	0.80	3.40	2.60	1.35	1.95	189	16.000	6011 6210	90	55 50	
244 550	94.50	75.50	0.80	3.45	2.65	1.39	2.00	206	13.300	6012	95	60	

This special design generates very small loads and accommodates large deflections.  
Material C75S Spring Steel.

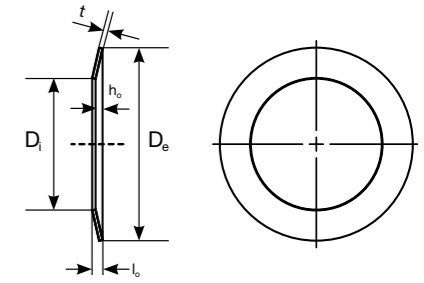

# Preload Springs

## Diameter 9.8 - 119 mm

Reference	Dimensions						Spring travel s and force F		Weight	Ball bearing type	Ball bearing		
	D <sub>e</sub> (mm)	D <sub>i</sub> (mm)	t (mm)	l <sub>o</sub> (mm)	h <sub>o</sub> (mm)	h <sub>o</sub> /t	at s = 0.75 h <sub>o</sub> s (mm)	f (N)			Per 1000 pieces (kg)	External dia (mm)	Internal dia (mm)
241 200	9.80	6.20	0.20	0.40	0.20	1.00	0.15	23	0.07	623 EL3	10	3	
241 400	12.80	7.20	0.25	0.50	0.25	1.00	0.19	29	0.17	624 EL4	13	4	
241 600	15.80	8.20	0.25	0.55	0.30	1.20	0.23	23	0.28	625 EL5 634 R4	16	5 4	
241 700	18.80	9.20	0.30	0.65	0.35	1.17	0.26	31	0.49	626 EL6 635 R5	16	6 5	
241 800	18.80	10.20	0.35	0.07	0.35	1.00	0.26	51	0.53	607 EL7	19	7	
241 900	21.80	12.30	0.35	0.75	0.40	1.14	0.30	46	0.68	608 EL8 627 R7	22	8 7	
242 100	23.70	14.30	0.40	0.90	0.50	1.25	0.38	81	0.86	609 EL9	24	9	
242 200	25.70	14.30	0.40	0.90	0.50	1.25	0.38	63	1.11	6000 629 R9	26	10 9	
242 300	27.70	17.30	0.40	1.00	0.60	1.50	0.45	80	1.13	6001	28	12	
242 500	29.70	17.40	0.40	1.10	0.70	1.75	0.53	83	1.41	6200	30	10	
242 600	31.70	20.40	0.40	1.10	0.70	1.75	0.53	81	1.42	6002 6201	32	15 12	
242 800	34.60	20.40	0.40	1.10	0.70	1.75	0.53	61	1.89	6300	35	10	
242 900	34.60	22.40	0.50	1.20	0.70	1.40	0.53	118	2.10	6003 6202	35	17 15	
243 000	36.60	20.40	0.50	1.30	0.80	1.60	0.60	110	2.81	6301	37	12	
243 100	39.60	25.50	0.50	1.30	0.80	1.60	0.60	110	2.78	6203	40	17	
243 200	41.60	25.50	0.50	1.40	0.90	1.80	0.68	113	3.28	6004 6302	42	20 15	
243 300	46.50	30.50	0.60	1.50	0.90	1.50	0.68	153	4.49	6005 6204 6303	47	25 20 17	
243 400	51.50	35.50	0.60	1.50	0.90	1.50	0.68	135	5.06	6205 6304	52	25 20	
243 500	54.50	40.50	0.60	1.50	0.90	1.50	0.68	141	4.82	6006	55	30	
243 600	61.50	40.50	0.70	1.80	1.10	1.57	0.83	176	9.12	6007 6206 6305	62	35 30 25	
243 700	67.50	50.50	0.70	1.70	1.00	1.43	0.75	161	8.51	6008	68	40	
243 800	71.50	45.50	0.70	2.10	1.40	2.00	1.05	185	12.99	6306	72	30	
243 900	71.50	50.50	0.70	2.10	1.40	2.00	1.05	218	10.90	6207	72	35	
244 000	74.50	55.50	0.80	1.90	1.10	1.38	0.83	211	11.99	6009	75	45	
244 100	79.50	50.50	0.80	2.30	1.50	1.88	1.13	228	18.40	6307	80	35	
244 200	79.50	55.50	0.80	2.30	1.50	1.88	1.13	263	15.78	6010 6208	80	50 40	
244 300	84.50	60.50	0.90	2.50	1.60	1.78	1.20	359	19.05	6209	85	45	
244 400	89.50	60.50	0.90	2.50	1.60	1.78	1.20	288	23.86	6308	90	40	
244 500	89.50	65.50	0.90	2.50	1.60	1.78	1.20	335	20.36	6011 6210	90	55 50	
244 600	94.50	75.50	1.00	2.20	1.20	1.20	0.90	325	19.57	6012	95	60	
244 700	99.00	65.50	1.00	2.60	1.60	1.60	1.20	292	33.64	6309	100	45	
244 800	99.00	70.50	1.00	2.60	1.60	1.60	1.20	335	29.44	6013 6211	100	65 55	
244 900	109.00	70.50	1.25	2.70	1.45	1.16	1.09	357	52.80	6310	110	50	
245 000	109.00	75.50	1.25	2.70	1.45	1.16	1.09	398	47.17	6014 6212	110	70 60	
245 100	114.00	90.50	1.25	2.45	1.20	0.96	0.90	398	36.49	6015	115	75	
245 200	119.00	75.50	1.25	2.80	1.55	1.24	1.16	320	64.71	6311	120	55	

## Diameter 119 - 358 mm

Reference	Dimensions						Spring travel s and force F		Weight	Ball bearing type	Ball bearing		
	D <sub>e</sub> (mm)	D <sub>i</sub> (mm)	t (mm)	l <sub>o</sub> (mm)	h <sub>o</sub> (mm)	h <sub>o</sub> /t	at s = 0.75 h <sub>o</sub> s (mm)	f (N)			Per 1000 pieces (kg)	External dia (mm)	Internal dia (mm)
245 300	119.00	85.50	1.25	2.80	1.55	1.24	1.16	393	52.28	6213	120	65	
245 400	124.00	90.50	1.25	3.00	1.75	1.40	1.31	445	54.75	6016 6214	125	80 70	
245 500	129.00	85.50	1.25	3.20	1.95	1.56	1.46	4.05	71.28	6312	130	60	
245 600	129.00	95.50	1.25	3.20	1.95	1.56	1.46	500	57.31	6017 6215	130	85 75	
245 700	139.00	90.50	1.25	3.25	2.00	1.60	1.50	354	85.11	6313	140	65	
245 800	139.00	101.00	1.25	3.25	2.00	1.60	1.50	429	69.58	6018 6216	140	90 80	
245 900	149.00	95.50	1.50	3.20	1.70	1.13	1.28	379	120.10	6314	150	70	
246 000	149.00	106.00	1.50	3.20	1.70	1.13	1.28	450	100.50	6020 6217	150	100 85	
246 100	159.00	101.00	1.50	3.50	2.00	1.33	1.50	412	138.50	6315	160	75	
246 200	159.00	111.00	1.50	3.50	2.00	1.33	1.50	477	118.90	6021 6218	160	105 90	
246 300	169.00	111.00	1.50	3.80	2.30	1.53	1.73	470	149.20	6316	170	80	
246 400	169.00	121.00	1.50	3.80	2.30	1.53	1.73	546	127.70	6022 6219	170	110 95	
246 500	179.00	121.00	2.00	4.20	2.20	1.10	1.65	864	213.10	6317	180	95	
246 600	179.00	126.00	2.00	4.20	2.20	1.10	1.65	928	197.80	6024 6220	180	120 100	
246 700	189.00	121.00	2.00	4.30	2.30	1.15	1.73	759	258.30	6318	190	90	
246 800	189.00	131.00	2.00	4.30	2.30	1.15	1.73	858	227.10	6221	190	105	
246 900	198.00	131.00	2.00	4.50	2.50	1.25	1.88	812	270.00	6319	200	95	
247 000	198.00	141.00	2.00	4.50	2.50	1.25	1.88	923	236.40	6026 6222	200	130 110	
247 100	213.00	151.00	2.25	4.50	2.25	1.00	1.69	941	310.90	6224 6320	215	120 100	
247 200	223.00	161.00	2.25	4.60	2.35	1.04	1.76	942	328.00	6030 6321	225	150 105	
247 300	228.00	161.00	2.25	4.95	2.70	1.20	2.03	1036	359.20	6226	230	130	
247 400	238.00	161.00	2.25	5.25	3.00	1.33	2.25	1021	423.80	6032 6322	240	160 110	
247 500	248.00	171.00	2.50	5.00	2.50	1.00	1.88	1005	494.50	6228	250	140	
247 600	258.00	171.00	2.50	5.50	3.00	1.20	2.25	1106	572.20	6034 6324	260	170 120	
247 700	268.00	181.00	2.50	5.70	3.20	1.28	2.40	1155	598.70	6230	270	150	
247 800	278.00	181.00	2.50	6.00	3.50	1.40	2.63	1155	682.70	6036 6326	280	180 130	
247 900	288.00	191.00	2.75	5.75	3.00	1.09	2.25	1145	783.70	6038 6232	290	190 160	
248 000	298.00	191.00	2.75	6.35	3.60	1.31	2.70	1307	883.00	6328	300	140	
248 100	308.00	202.00	3.00	6.10	3.10	1.03	2.33	1300	995.20	6040 6234	310	200 170	
248 200	318.00	212.00	3.00	6.20	3.20	1.07	2.40	1302	1034.00	6236 6330	320	180 150	
248 300	338.00	232.00	3.00	6.60	3.60	1.20	2.70	1415	1112.00	6044 6238 6332	340	220 190 160	
248 400	358.00	242.00	3.00	7.00	4.00	1.33	3.00	1424	1281.00	6048 6240 6334	360	240 200 170	

The load and deflections given are at spring deflection of 75% of the free height h<sub>o</sub>.  
 This is the recommended preload for installation of these disc springs.  
 Material C75S Spring Steel.



## Bearing Lock Nuts

The **Fine U-Nut** was developed to simplify the assembly and reduce costs involved in securing Ball Bearings.

The manufacturer has more than 30 years experience in Lock Nut Technology and their factory is ISO 9001 approved.

### Construction & Function

The **Fine U-Nut** is a one piece item where the locking function is performed by a spring peened into the top of the nut. In use the spring bears on the flank of the shaft thread with force  $P$  generating reaction  $P'$  in the screw threads with a resulting high friction torque (prevailing torque). The nut therefore remains locked in position.

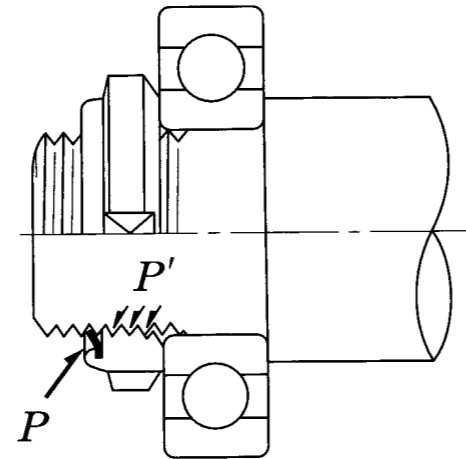

### Key Features:

- Secure locking without keyway and tab washer
- Unique slim body design
- Improved shaft strength and balance
- Simple infinite adjustment
- Re-usable up to 100 times
- Carbon, high carbon and stainless steel versions
- Resists vibration and shock
- Equally effective for rotation in either direction even with rapid reversals
- One piece construction reduces assembly time and stock items

### Materials

Material	JIS	ISO	BS
Low Carbon Steel	SS400 (or equivalent)	1.0044	43B
High Carbon Steel	S45C (or equivalent)	1.0503/1.1191/1.1201	070M46/080M46/080A47
Stainless Steel	SUS304 (or equivalent)	1.4301	304S31

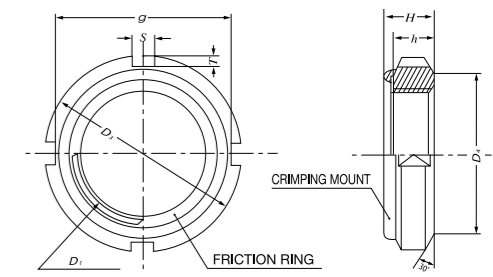

## Dimensions

Unit : mm

Designation of Thread D <sub>1</sub>	Low Carbon Reference	High Carbon Reference	Stainless Steel Reference	D <sub>3</sub>	D <sub>4</sub>	g	T	S	h	H	Perpendicularity of bearing surface
M10 x 0.75	FU00SS	FU00SC	FU00SUS	18	13.5	14.4	1.8	3	4	5.2	±0.3
M12 x 1.0	FU01SS	FU01SC	FU01SUS	22	17	18.4	1.8	3	4	5.4	±0.5
M15 x 1.0	FU02SS	FU02SC	FU02SUS	25	21	21.4	1.8	4	5	6.5	
M17 x 1.0	FU03SS	FU03SC	FU03SUS	28	24	24.2	1.9	4	5	6.4	
M20 x 1.0	FU04SS	FU04SC	FU04SUS	32	26	28.4	1.8	4	6	7.7	0.05
M25 x 1.5	FU05SS	FU05SC	FU05SUS	38	32	34	2	5	7	9.1	
M30 x 1.5	FU06SS	FU06SC	FU06SUS	45	38	41	2	5	7	9.1	
M35 x 1.5	FU07SS	FU07SC	FU07SUS	52	44	48	2	5	8	10.2	±0.8
M40 x 1.5	FU08SS	FU08SC	FU08SUS	58	50	53	2.5	6	9	11.2	±1.0
M45 x 1.5	FU09SS	FU09SC	FU09SUS	65	56	60	2.5	6	10	12.5	
M50 x 1.5	FU10SS	FU10SC	FU10SUS	70	61	65	2.5	6	11	13.5	
M55 x 2.0	FU11SS	FU11SC	FU11SUS	75	67	69	3	7	11	13.5	±1.5
M60 x 2.0	FU12SS	FU12SC	FU12SUS	80	73	74	3	7	11	13.5	
M65 x 2.0	FU13SS	FU13SC	FU13SUS	85	79	79	3	7	12	15	
M70 x 2.0	FU14SS	FU14SC	FU14SUS	92	85	85	0	3.5	12	15	0.07
M75 x 2.0	FU15SS	FU15SC	FU15SUS	98	90	91	-0.5	3.5	13	15.8	
M80 x 2.0	FU16SS	FU16SC	FU16SUS	105	95	98	3.5	8	15	18.6	
M85 x 2.0	FU17SS	FU17SC	FU17SUS	110	102	103	3.5	8	16	19.2	±1.5
M90 x 2.0	FU18SS	FU18SC	FU18SUS	120	108	112	4	10	16	20.3	
M95 x 2.0	FU19SS	FU19SC	FU19SUS	125	113	117	4	10	17	21.3	
M100 x 2.0	FU20SS	FU20SC	FU20SUS	130	120	122	4	10	18	22.3	0.10
M105 x 2.0	-	FU21SC	-	140	126	130	4	14	18	22.3	
M110 x 2.0	-	FU22SC	-	145	133	135	5	12	19	23.3	
M115 x 2.0	-	FU23SC	-	150	137	140	5	12	19	23.3	±1.5
M120 x 2.0	-	FU24SC	-	155	138	145	5	12	20	24.3	
M125 x 2.0	-	FU25SC	-	160	148	150	5	12	21	25.4	
M130 x 2.0	-	FU26SC	-	165	149	155	5	12	21	25.4	±1.5
M135 x 2.0	-	FU27SC	-	175	160	163	6	14	22	26.6	
M140 x 2.0	-	FU28SC	-	180	160	168	6	14	22	26.6	
M145 x 2.0	-	FU29SC	-	190	171	178	6	14	24	28.6	±1.5
M150 x 2.0	-	FU30SC	-	195	171	183	6	14	24	28.3	

Thread Accuracy: ISO6H (JIS CLASS 2).  
Sockets and C Spanners available on request.

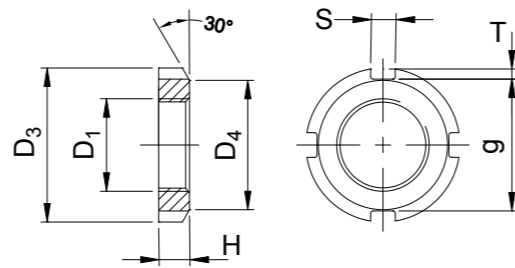

## Bearing Lock Nuts

### Dimensions

Unit: mm

Thread Size D <sub>1</sub>	Carbon Steel	Stainless Steel	D <sub>3</sub>	D <sub>4</sub>	g	T	S	H	Tab Washer
M10 x 0.75	KM00	KM00SS	18	13.5	14	2	3	4	MB0
M12 x 1.0	KM01	KM01SS	22	17	18				MB1
M15 x 1.0	KM02	KM02SS	25	21	21		4	5	MB2
M17 x 1.0	KM03	KM03SS	28	24	24				MB3
M20 x 1.0	KM04	KM04SS	32	26	28		5	6	MB4
M25 x 1.5	KM05	KM05SS	38	32	34				MB5
M30 x 1.5	KM06	KM06SS	45	38	41		6	7	MB6
M35 x 1.5	KM07	KM07SS	52	44	48				MB7
M40 x 1.5	KM08	KM08SS	58	50	53	2.5	6	9	MB8
M45 x 1.5	KM09	KM09SS	65	56	60				MB9
M50 x 1.5	KM10	KM10SS	70	61	65	3	7	11	MB10
M55 x 2.0	KM11	KM11SS	75	67	69				MB11
M60 x 2.0	KM12	KM12SS	80	73	74	3.5	8	12	MB12
M65 x 2.0	KM13	KM13SS	85	79	79				MB13
M70 x 2.0	KM14	KM14SS	92	85	85	4	10	13	MB14
M75 x 2.0	KM15	KM15SS	98	90	91				MB15
M80 x 2.0	KM16	KM16SS	105	95	98	4	10	15	MB16
M85 x 2.0	KM17	KM17SS	110	102	103				MB17
M90 x 2.0	KM18	KM18SS	120	108	112	4	10	16	MB18
M95 x 2.0	KM19	KM19SS	125	113	117				MB19
M100 x 2.0	KM20	KM20SS	130	120	122	4	10	18	MB20

Sockets and C Spanners available on request.

### Materials

Material	JIS		ISO		BS	
	Nut	Washer	Nut	Washer	Nut	Washer
Carbon Steel	C45	DC01	1.0503	1.0330	070M46	CR4
Stainless Steel	SUS304	SUS304	1.4301	1.4301	304S31	304S31

## Other Products

### Thin Section Bearings

- Bore sizes from 1" to 40"
- Precision to ABEC 7
- Radial, angular and 4 point contact versions
- Standard materials - SAE 52100 & 440C
- Shielded and sealed versions
- Duplex and super duplex configurations
- Special materials for hostile environments
- ISO 9001 and AS9100 approved factory



### High Precision Ball Bearings

- Metric and imperial sizes from 1mm to 35mm and .040" - .625" bore
- Precision to ABEC 9
- Angular contact spindle
- Duplex and super duplex
- Special sizes and assemblies
- Hybrid and ceramic
- High corrosion resistant steel X30 CrMoN 15-1
- ISO9001 approved factory



### Labyrinth Sealing Rings

- Protect bearings and seals in hot, dirty and abrasive environments
- Simple, cost effective design
- 15mm to 1300mm nominal bore or shaft diameters
- Standard materials to 300°C nickel chrome to 720°C
- Special sizes produced economically
- ISO9001 and TS16949 approved factory



### Disc Springs

- Standard and special sizes from 6mm to 250mm OD
- Special sizes to 1,000mm outside diameter and 80mm thick
- Standard range manufactured from spring steel
- High alloy steels, Nickel and Copper Alloys available for hostile conditions
- Special range for pre-loading bearings
- Manufactured to DIN2092 and DIN2093 standards
- ISO 9001 and TS16949 approved factory



### Safety Washers

- Reliable and economic vibration resistant washers
- Size range from 1.6mm to 36mm bolt
- Wide range of materials and finishes
- No deformation of fastener stem
- Minimum damage to mating surfaces
- V and VS styles to suit most types of bolts
- ISO 9001 and TS16949 approved factory



### Load Washers

- High axial loads
- Size range from 1.6mm to 36mm bolt
- Wide range of materials and finishes
- No deformation of fastener stem
- Minimum damage to mating surfaces
- HDS and HS styles to suit most types of bolts
- Suitable for captive fitting
- ISO 9001 and TS16949 approved factory





**abis**  
precision ball bearings

***Integrity*** • ***Expertise*** • ***Commitment***

**IEC Limited**, Harwell Road, Nuffield Estate, Poole, Dorset BH17 0BD, Great Britain

Registered in England 1925337

05/2016



RS00117

**T** 01202 339559  
**F** 01202 680101  
**E** info@iecltd.co.uk  
**W** www.iecltd.co.uk